



Community Development
221 E Clark St
Albert Lea, MN 56007
Phone: 507-377-4340

RESIDENTIAL DECKS INFORMATION SHEET

Building Permits: A permit is required if the deck is over 30" off the ground, regardless if it is attached or unattached to the house. A permit is not required for a deck if it is less than 30" off the ground and not attached to the house.

Setbacks

- A. Decks up to 18" above the ground:
 - 1. May extend into the required interior side yard setback a distance not to exceed three (3) feet, but shall not in any case be nearer than 3 feet from the interior side property line.
 - 2. May extend into the required front and rear yard setback a distance not to exceed eight (8) feet, but shall not in any case be nearer than 15 feet from the front and rear property line.
- B. Decks higher than 18" above the ground:
 - 1. May extend into the required interior side yard setback a distance not to exceed three (3) feet, but shall not in any case be nearer than 3 feet from the interior side property line.
 - 2. May extend into the required front and rear yard setback a distance not to exceed six (6) feet, but shall not in any case be nearer than 15 feet from the front and rear property line.
- C. No deck may extend into the required exterior side yard setback on a corner lot except where there is an existing entrance facing an exterior side yard on a corner lot, steps and landing may extend up to three (3) feet into the required exterior side yard.
- D. No deck extending into any required setback shall be covered from above or along the sides.

Revised April 2018

Deck Plan Checklist

Please check that you have all the required items listed below on your plans before submitting your plans and application.

Site Plan

- Map showing property lines and all existing structures (*may use an aerial printout from Beacon*)
- Proposed deck location and distance from property line & existing structure(s)

Footing Detail

- Depth of footings
- Sizes of footings
- How they will be constructed (rebar, anchor bolts, base plate)

Framing Detail

- Ledger size; type of anchors and spacing
- Joist size with type of attachment
- Beam sizes & spacing
- Post sizes, spacing & height
- Cantilevers with measurements
- Elevations off the ground
- Lateral withdrawal anchors
- Proper counter flashing at deck ledger and anywhere else required

Stair Detail

- Material sizes, spacing, and dimensions of rise & run
- How it is constructed; special hangers

- Decking material and orientation from joists
- Handrail/guardrail detail (if deck is over 30" from surface below)
 - Height & post spacing
 - Spindle spacing/special hangers
- List of any other hangers/ fasteners

Call Gopher State One Call for utility locations at least two working days before you dig – 1-800-252-1166 or 651-454-0002. Or 811



ELECTRICAL

NEC 210.52(E)(3) Balconies, decks and porches, regardless of size, that are accessible from inside a dwelling unit shall have at least one receptacle installed within the perimeter.

R303.7 Exterior stairways shall be provided with a means to illuminate the stairs, including the landings and treads. Exterior stairways shall be provided with an artificial light source located in the immediate vicinity of the top landing of the stairway.

The illumination of exterior stairways shall be controlled from inside the dwelling unit.

Exception: Lights that are continuously illuminated or automatically controlled.

MATERIALS

Fasteners

Nails and other hardware must be hot-dipped zinc-coated (galvanized), stainless steel or equal. Screws should be either hot-dipped galvanized or electroplated with a polymer coating. 12d nails are recommended on nominal 2-inch decking. 10d nails are recommended for 5/4" decking.

With lag screws, use a flat washer under the head. Use washers under the nut and head of machine bolts and just under the nut of carriage bolts.

Lumber

All wood used in deck construction must be pressure treated lumber or wood that is naturally resistant to decay such as redwood or cedar.

Wood used aboveground, in contact with the ground, or belowground requires different degrees of treatment. Check the labels of the material you are buying to determine where it can be used. *Because some preservative treatments are very corrosive, make sure that any fasteners or metal connectors used in the construction of your deck are approved by the manufacturer for use with treated wood.*

DECKING

Materials commonly used for decking include standard dimension lumber (either 2X4 or 2X6), radius-edged decking, or a manufactured decking product.

Radius-edged Patio Decking (5/4 decking) has been specifically developed for outdoor decks. *Redwood and cedar patio decking is intended to be used flat-wise in load-bearing applications where spans do not exceed 16" o.c. (12" o.c. when installed diagonally to joists). Southern pine decking may span 24" o.c. or 16" o.c. when installed diagonally to joists.*

Manufactured decking products maybe used only when meeting ASTM D 7032 or when approved by the Building Department. Approval is based on the material carrying an ICC Evaluation Services Report. Decking without a report may not be approved. Ask the decking supplier to provide you with a copy of the research report. The Building Department maintains a list of composite decking materials that meet US building codes that is available upon request. **Caution—some manufactured deck products are approved for decking but not for stair treads. In some cases where manufactured decking is approved for stairs, the spacing of supports maybe significantly reduced compared to use on the deck itself. Read the research report for further information.**

MAXIMUM DECK BOARD SPANS	
2x6 OR 5/4 SOUTHERN PINE PERPENDICULAR TO JOIST	24" O.C.
5/4 CEDAR OR REDWOOD AND 2X4 PERPENDICULAR TO JOIST OR 5/4 SOUTHERN PINE OR 2X6 AT 45 DEGREES TO JOIST	16" O.C.
5/4 AND 2X4 AT 45 DEGREES TO JOIST	12" O.C.

FOOTINGS

Footings supporting a 4x4 column must be not less than 6-inch diameter. Post footings supporting columns larger than 4x4 must be 8-inch diameter or larger. The bottom of post footings may be “belled” to achieve the desired minimum bearing area. The base of the footing must be at least **42 inches** below finished grade. Rebar is recommended. Center the column on the footing secured by a pin or connector. Posts imbedded in the ground must be 60% C.C.A. or equal. Using a fiberboard tube will allow elevation of the top of the footing above finished grade to provide protection of the wood post from lawn mowers and trimmers.

UNDERSTANDING LOAD PATHS

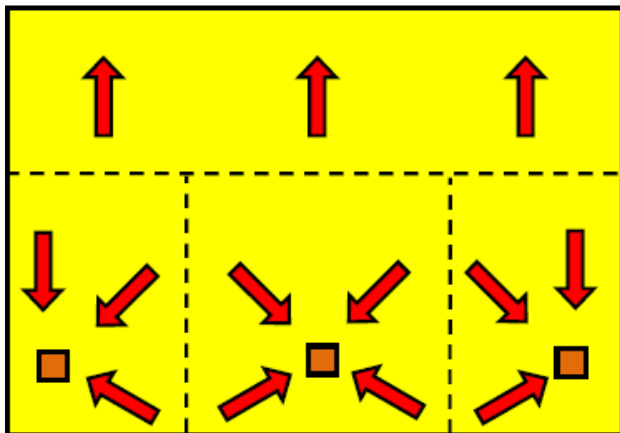

Loads are assumed to be uniform across the floor

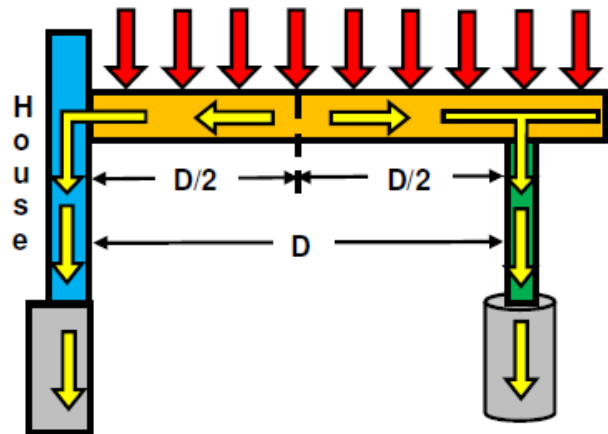

Deck footings should be sized according to the following table. Footings must extend **at least 42 inches below grade** (frost line) except for decks that are not connected to a dwelling. **The minimum compressive strength of concrete used for deck footings is 2500 psi.**

DECK FOOTING SIZES (1500 psf soils) – NOT FOR USE WITH HOT TUBS							
Max. Area of Deck Supported in Sq Ft	Footing Diameter Required in Inches	Max. Area of Deck Supported in Sq Ft	Footing Diameter Required in Inches	Max. Area of Deck Supported in Sq Ft	Footing Diameter Required in Inches	Max. Area of Deck Supported in Sq Ft	Footing Diameter Required in Inches
10	8	23	12	41	16	65	20
13	9	27	13	47	17	72	21
16	10	32	14	53	18	79	22
19	11	36	15	59	19	86	23

Required footing sizes are determined by calculating the area of the deck supported by each footing. Loads shall be assumed to be equally shared between the supporting elements. **Don't over look cantilevers. The minimum compressive strength of concrete used for deck footings is 2500 psi.**

THE REQUIRED AREA OF THE COLUMN SHOULD FULLY BEAR ON THE FOOTING

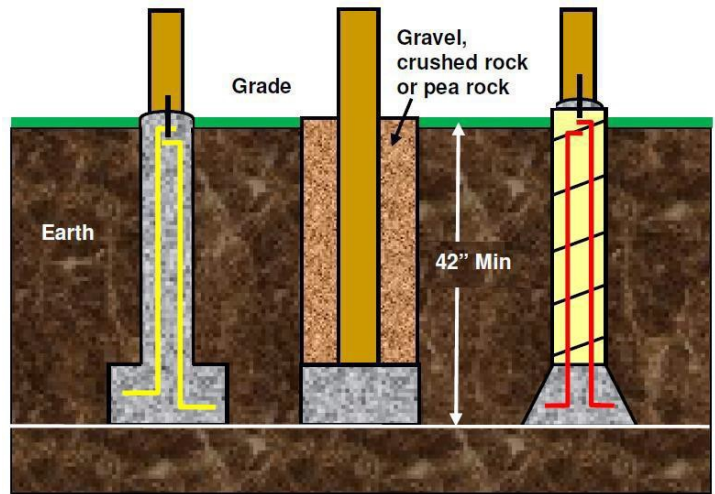
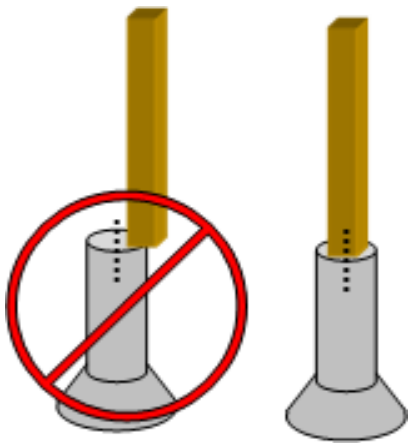

The minimum compressive strength of concrete used for deck footings is 2500 psi.

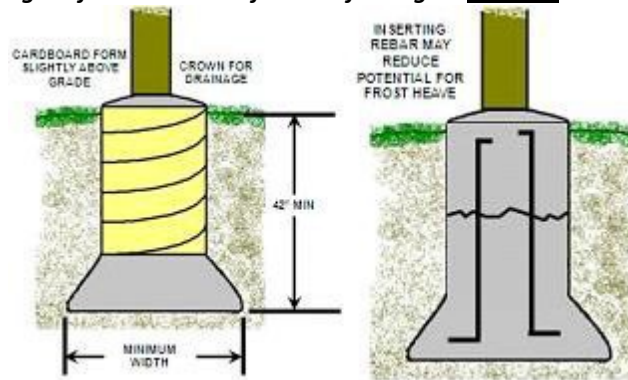

WHERE DO I PUT MY FOOTINGS?

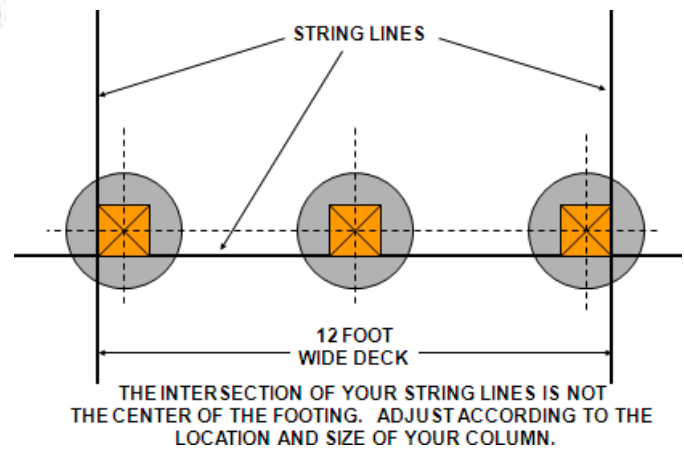
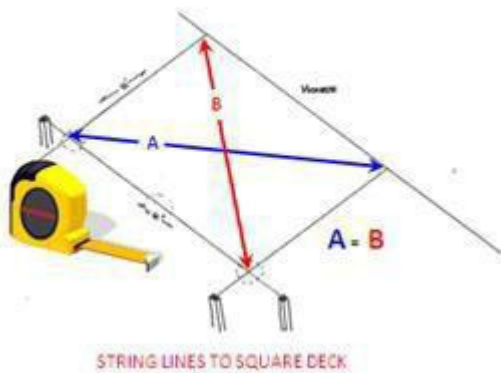

ANCHORING POST BASE

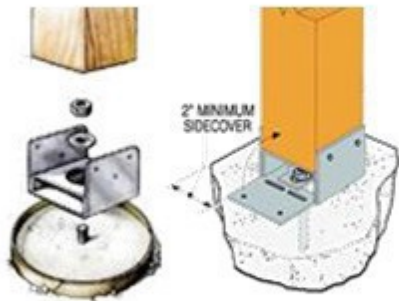

Follow manufacturers installation specifications.



Not allowed - connection must be made using a field inspectable means of connection.

DECKFRAMING ATTACHMENT OF LEDGER BOARD TO WOOD JOISTS (2X6, 2X8, 2X10, 2X12) (Caution: 2x6 and 2x8 joists will require underside floor protection with 5/8" treated plywood)

Make sure the ledger is securely attached to the dwelling. Install metal flashing at top and caulk sides.

TABLE R507.2 FASTENER SPACING FOR ASOUTHERN PINE OR HEM-FIR DECK LEDGER AND A 2-INCH-NOMINAL SOLID-SAWN SPRUCE-PINE-FIR BAND JOIST ^{c, f, and g} (Deck live load = 40 psf, deck dead load = 10 psf)							
JOIST SPAN	6' and less	6'1" to 8'	8'1" to 10'	10'1" to 12'	12'1" to 14'	14'1" to 16'	16'1" to 18'
Connection details	On-center spacing of fasteners d and e ^e						
1/2 inch diameter lag screw with 1/32 inch maximum sheathing ^a	30	23	18	15	13	11	10
1/2 inch diameter bolt with 1/32 inch maximum sheathing	36	36	34	29	24	21	19
1/2 inch diameter bolt with 1/32 inch maximum sheathing and 1/2 inch stacked washers ^{b, h}	36	36	29	24	21	18	16

a. The tip of the lag screw shall fully extend beyond the inside face of the band joist.
 b. The maximum gap between the face of the ledger board and face of the wall sheathing shall be 1/2 inch.
 c. Ledgers shall be flashed to prevent water from contacting the house band joist.
 d. Lag screws and bolts shall be staggered in accordance with Section R507.2.1.
 e. Deck ledger shall be minimum 2 x 8 pressure-preservative-treated No. 2 grade lumber, or other approved materials as established by standard engineering practice.
 f. When solid-sawn pressure-preservative-treated deck ledgers are attached to a minimum 1-inch-thick engineered wood product (structural composite lumber, laminated veneer lumber or wood structural panel band joist), the ledger attachment shall be designed in accordance with accepted engineering practice.
 g. A minimum 1 x 9/8 Douglas Fir laminated veneer lumber rim board shall be permitted in lieu of the 2-inch nominal band joist.
 h. Wood structural panel sheathing, gypsum board sheathing or foam sheathing not exceeding 1 inch in thickness shall be permitted. The maximum distance between the face of the ledger board and the face of the band joist shall be 1 inch.

Capacity of lag or carriage bolts shall not exceed 400 lb's per bolt unless design provided.

TABLE 507.2.1 PLACEMENT OF LAG SCREWS AND BOLTS IN DECK LEDGERS AND BAND JOISTS				
MINIMUM END AND EDGE DISTANCES AND SPACING BETWEEN ROWS				
	TOP EDGE	BOTTOM EDGE	ENDS	ROW SPACING
Ledger ^a	2 inches _s	1/4 inch	2 inch ^b	1 1/8 inches _{es}
Band Joist	3/4 inches	2 inches	2 inch ^b	1 1/8 inches _{es}

a. Lag screws or bolts shall be staggered from the top to the bottom along the horizontal run of the deck ledger in accordance with Figure R507.2.1(1).
 b. Maximum 5 inches.
 c. For engineered rim joists, the manufacturer's recommendations shall govern.
 d. The minimum distance from bottom row of lag screws or bolts to the top edge of the ledger shall be in accordance with Figure R507.2.1(1).

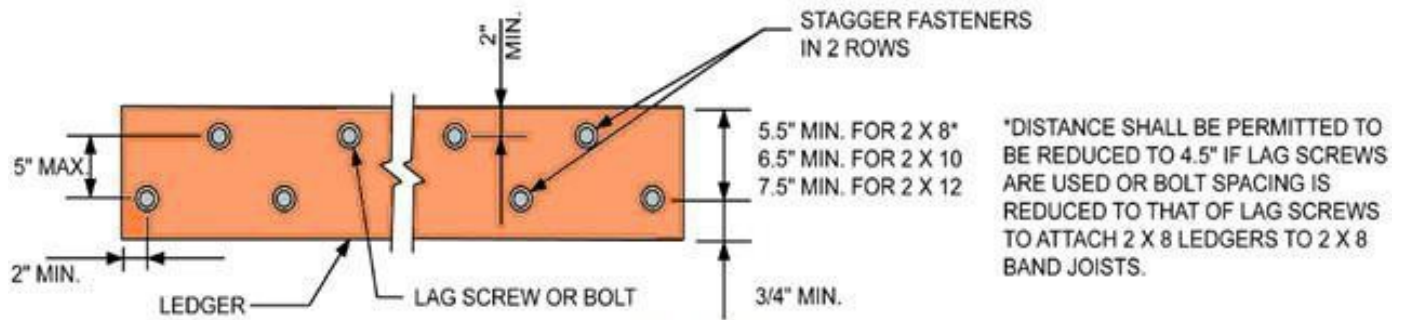
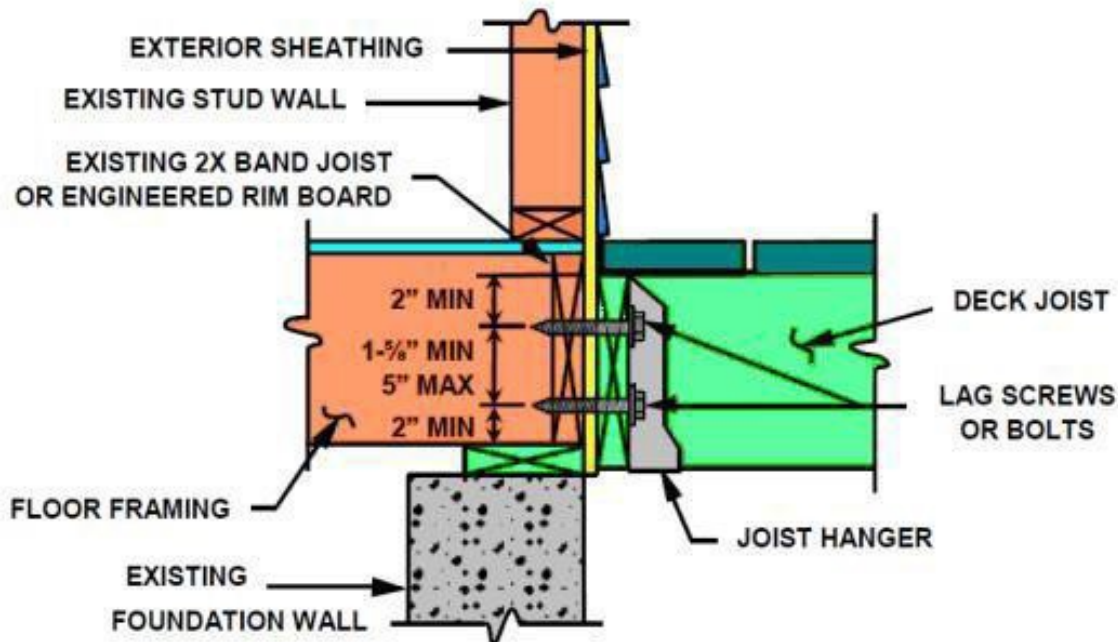

FIGURE R507.2.1(1)
PLACEMENT OF LAG SCREWS AND BOLTS IN LEDGERS

PLACEMENT OF LAG SCREWS AND BOLTS IN BAND JOISTS



1/2" DIAMETER LAG SCREWS MINIMUM



LEDGER FLASHING DETAIL

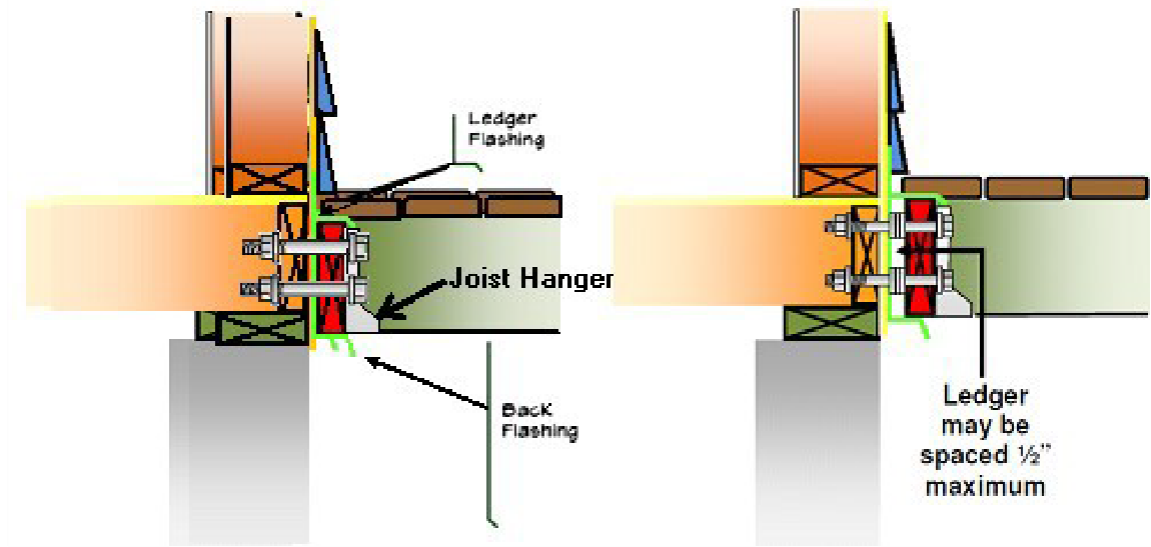

LATERAL LOAD CONNECTIONS TWO MINIMUM PER DECK

(See "Alternate Methods" page 10)

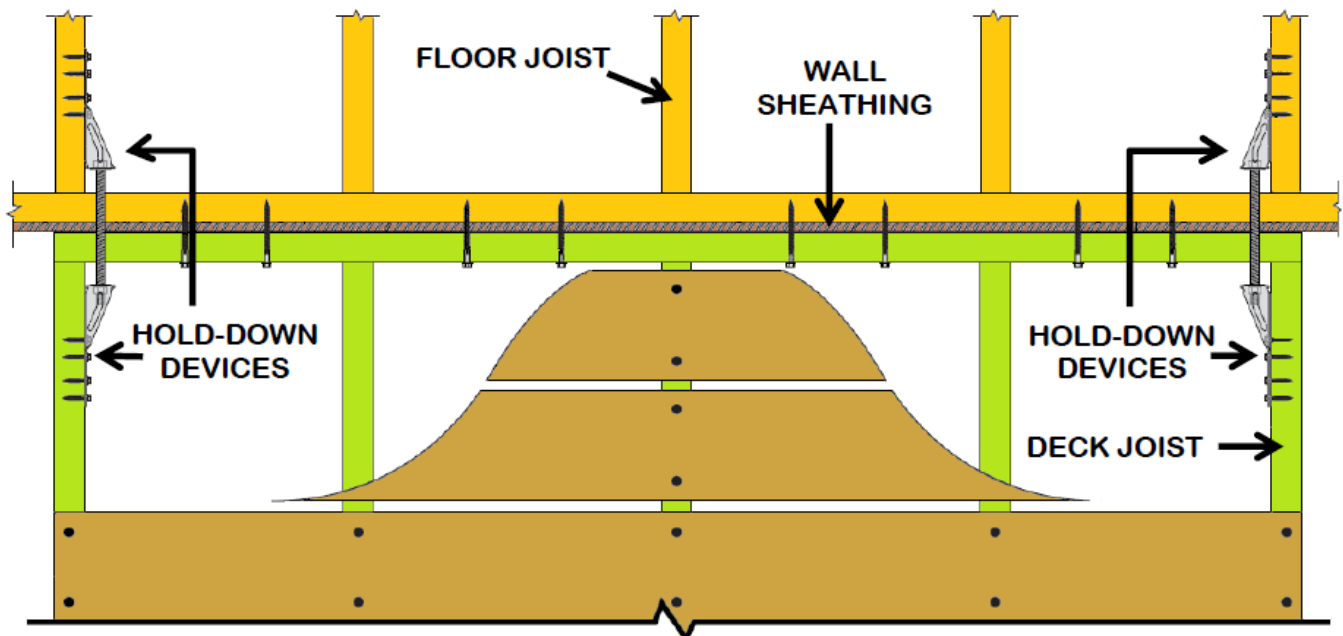

- HOLD-DOWN TENSION DEVICES MUST BE INSTALLED IN NOT LESS THAN TWO LOCATIONS PER DECK
- EACH DEVICE MUST HAVE AN ALLOWABLE STRESS DESIGN CAPACITY OF NOT LESS THAN 1500 POUNDS.
- FLOOR SHEATHING IN THE DWELLING MUST BE NAILED TO THE JOISTS TO WHICH HOLD DOWNS ARE CONNECTED AT 6" MAXIMUM O.C.
- ALTERNATIVELY THE DECK MAY BE DESIGNED TO BE SELF SUPPORTING OR A DESIGN MAY BE PROVIDED BY A LICENSED DESIGN PROFESSIONAL.

FLOOR JOISTS
PERPENDICULAR TO DECK
LEDGER

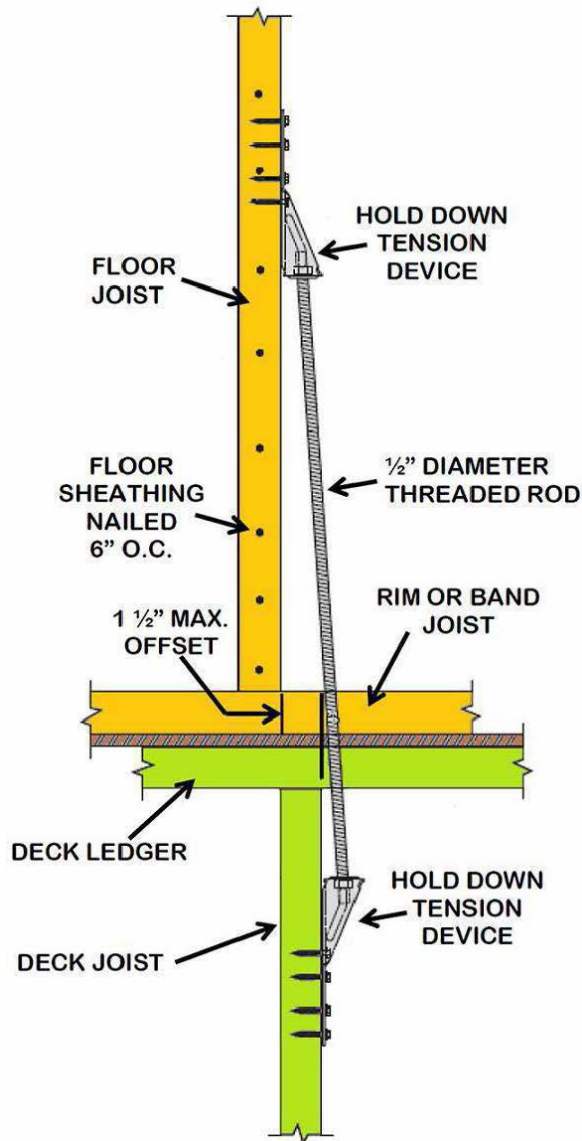

FLOOR JOISTS
PARALLEL TO DECK
LEDGER

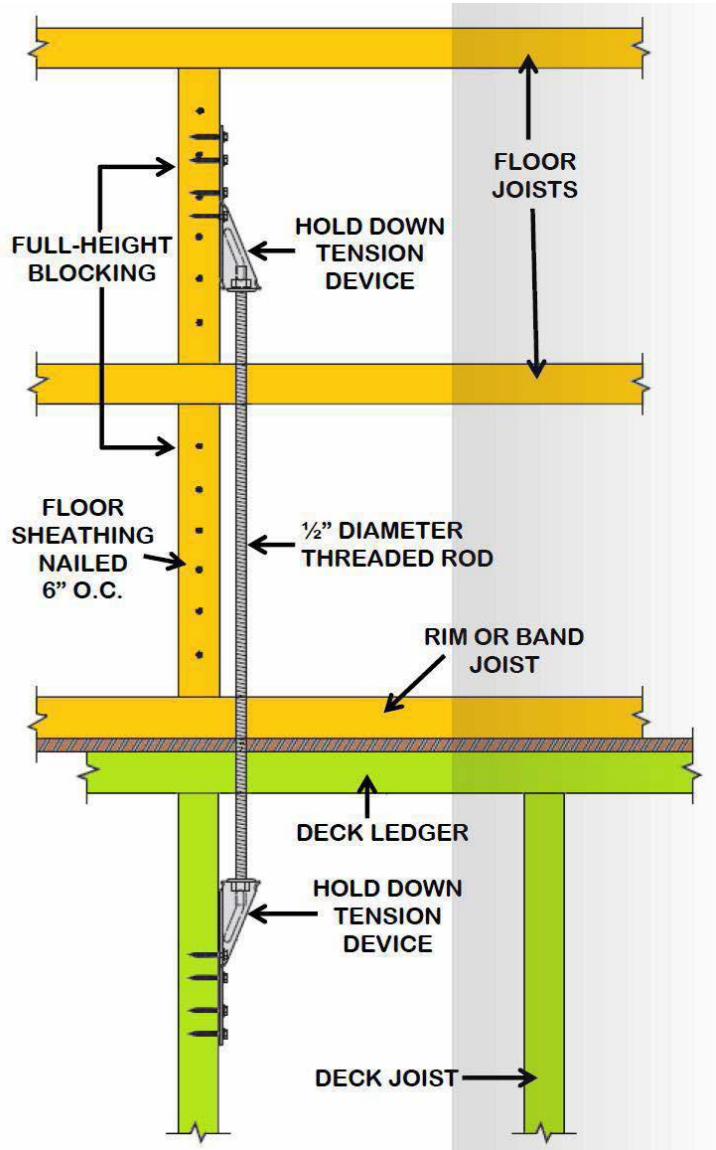

WHEN THERE IS NO ACCESS TO THE
TOP OF THE FLOOR SHEATHING

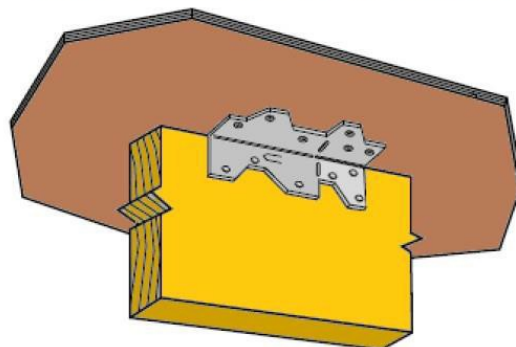

INSTALL APPROVED CONNECTORS PER THE
MANUFACTURER'S INSTALLATION INSTRUCTIONS

IN ALL CASES, MANUFACTURER'S INSTALLATION INSTRUCTIONS MUST BE FOLLOWED

DECK BEAM SPAN LENGTHS^{a, b, g} (feet - inches)

SPECIES ^c	SIZE ^d	DECK JOIST SPAN LESS THAN OR EQUAL TO: (feet)						
		6	8	10	12	14	16	18
Southern pine	1 – 2 × 6	4-11	4-0	3-7	3-3	3-0	2-10	2-8
	1 – 2 × 8	5-11	5-1	4-7	4-2	2-10	3-7	3-5
	1 – 2 × 10	7-0	6-0	5-5	4-11	4-7	4-3	4-0
	1 – 2 × 12	8-3	7-1	6-4	5-10	5-5	5-0	4-9
	2 – 2 × 6	6-11	5-11	5-4	4-10	4-6	4-3	4-0
	2 – 2 × 8	8-9	7-7	6-9	6-2	5-9	5-4	5-0
	2 – 2 × 10	10-4	9-0	8-0	7-4	6-9	6-4	6-0
	2 – 2 × 12	12-2	10-7	9-5	8-7	8-0	7-6	7-0
	3 – 2 × 6	8-2	7-5	6-8	6-1	5-8	5-3	5-0
	3 – 2 × 8	10-10	9-6	8-6	7-9	7-2	6-8	6-4
	3 – 2 × 10	13-0	11-3	10-0	9-2	8-6	7-11	7-6
	3 – 2 × 12	15-3	13-3	11-10	10-9	10-0	9-4	8-10
Douglas fir-larch ^e , hem-fir ^e , spruce-pine-fir ^e , redwood, western cedars, ponderosa pine ^f , red pine ^f	3 × 6 or 2 – 2 × 6	5-5	4-8	4-2	3-10	3-6	3-1	2-9
	3 × 8 or 2 – 2 × 8	6-10	5-11	5-4	4-10	4-6	4-1	3-8
	3 × 10 or 2 – 2 × 10	8-4	7-3	6-6	5-11	5-6	5-1	4-8
	3 × 12 or 2 – 2 × 12	9-8	8-5	7-6	6-10	6-4	5-11	5-7
	4 × 6	6-5	5-6	4-11	4-6	4-2	3-11	3-8
	4 × 8	8-5	7-3	6-6	5-11	5-6	5-2	4-10
	4 × 10	9-11	8-7	7-8	7-0	6-6	6-1	5-8
	4 × 12	11-5	9-11	8-10	8-1	7-6	7-0	6-7
	3 – 2 × 6	7-4	6-8	6-0	5-6	5-1	4-9	4-6
	3 – 2 × 8	9-8	8-6	7-7	6-11	6-5	6-0	5-8
	3 – 2 × 10	12-0	10-5	9-4	8-6	7-10	7-4	6-11
	3 – 2 × 12	13-11	12-1	10-9	9-10	9-1	8-6	8-1

For SI: 1 inch = 25.4 mm, 1 foot = 304.8 mm, 1 pound per square foot = 0.0479 kPa, 1 pound = 0.454 kg.

- a. Ground snow load, live load = 40 psf, dead load = 10 psf, L/Δ = 360 at main span, L/Δ = 180 at cantilever with a 220-pound point load applied at the end.
- b. Beams supporting deck joists from one side only.
- c. No. 2 grade, wet service factor.
- d. Beam depth shall be greater than or equal to depth of joists with a flush beam condition.
- e. Includes incising factor.
- f. Northern species. Incising factor not included.
- g. Beam cantilevers are limited to the adjacent beam's span divided by 4.

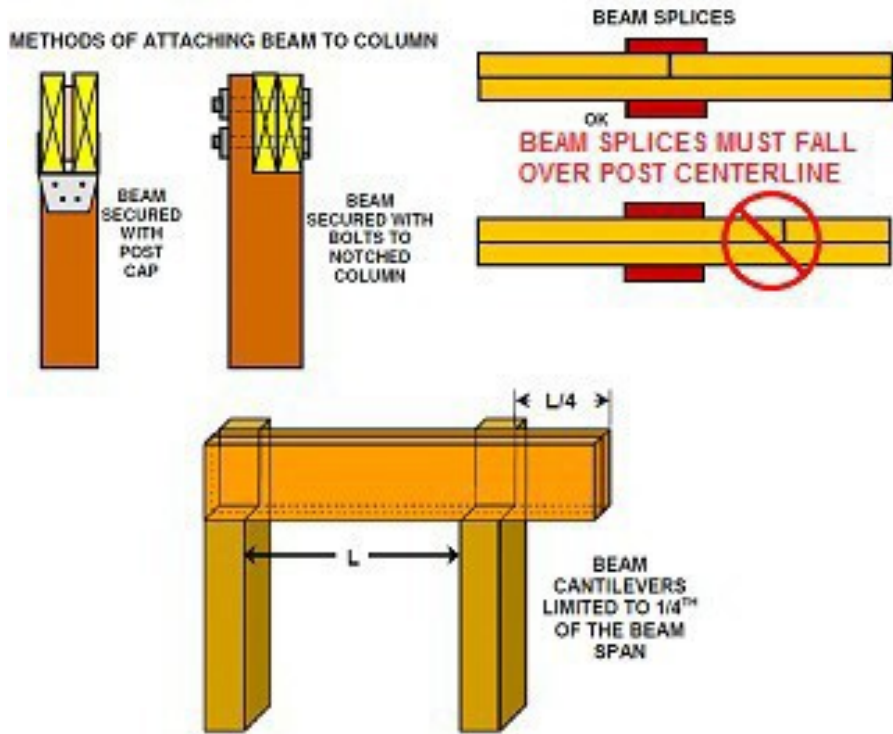

COLUMNS

		MAXIMUM POST HEIGHT IN FEET													
SPECIES	SIZE	SQUARE FEET OF DECK SUPPORTED													
		36	48	60	72	84	96	108	120	132	144	156	165	180	192
SOUTHERN PINE	4X4	10	10	10	9	9	8	8	7	7	6	6	6	6	6
	4X6	14	14	13	12	11	10	10	9	9	8	8	8	7	7
	6X6	17	17	17	17	17	17	17	17	16	16	15	14	13	13
REDWOOD CEDAR	4X4	10	10	9	8	7	7	6	6	5	4				
	4X6	14	13	12	11	10	9	8	8	7	7	7	6	6	5
	6X6	17	17	17	17	17	16	13	7						

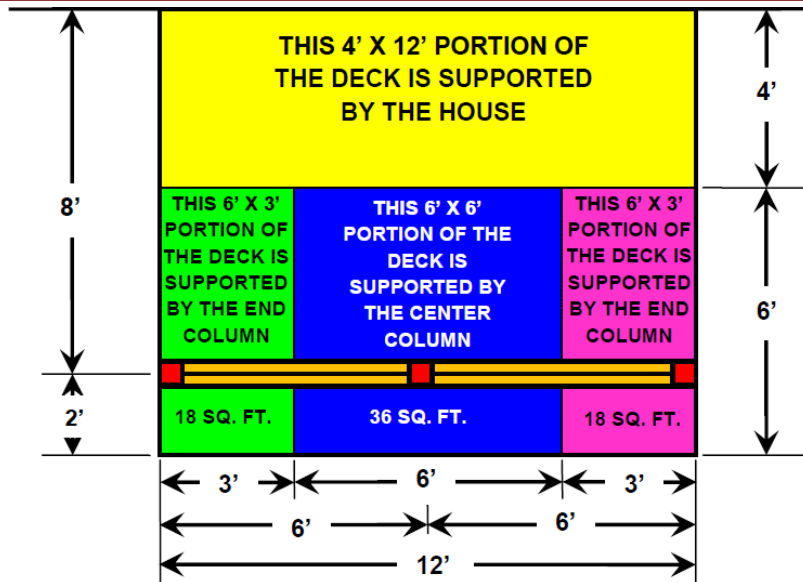

JOISTS

Table 2. Maximum Joist Spans and Overhangs.¹

Species	Size	Joist Spacing (o.c.)					
		12"	16"	24"	12"	16"	24"
		Allowable Span ² (L _J)			Allowable Overhang ³ (L _O)		
Southern Pine	2x6 ⁶	9' - 11"	9' - 0"	7' - 7"	1' - 0"	1' - 1"	1' - 3"
	2x8	13' - 1"	11' - 10"	9' - 8"	1' - 10"	2' - 0"	2' - 4"
	2x10	16' - 2"	14' - 0"	11' - 5"	3' - 1"	3' - 5"	2' - 10"
	2x12	18' - 0" ⁷	16' - 6"	13' - 6"	4' - 6"	4' - 2"	3' - 4"
Douglas Fir- Larch, Hem-Fir, Spruce-Pine-Fir ⁴	2x6 ⁶	9' - 6"	8' - 4"	6' - 10"	0' - 11"	1' - 0"	1' - 2"
	2x8	12' - 6"	11' - 1"	9' - 1"	1' - 8"	1' - 10"	2' - 2"
	2x10	15' - 8"	13' - 7"	11' - 1"	2' - 10"	3' - 2"	2' - 9"
	2x12	18' - 0" ⁷	15' - 9"	12' - 10"	4' - 4"	3' - 11"	3' - 3"
Redwood, Western Cedars, Ponderosa Pine ⁵ , Red Pine ⁵	2x6 ⁶	8' - 10"	8' - 0"	6' - 10"	0' - 9"	0' - 10"	0' - 11"
	2x8	11' - 8"	10' - 7"	8' - 8"	1' - 5"	1' - 7"	1' - 9"
	2x10	14' - 11"	13' - 0"	10' - 7"	2' - 5"	2' - 7"	2' - 8"
	2x12	17' - 5"	15' - 1"	12' - 4"	3' - 7"	3' - 9"	3' - 1"

1. Assumes 40 psf live load, 10 psf dead load, No. 2 stress grade, and wet service conditions.

2. Assumes L/360 deflection.

3. Maximum allowable overhang cannot exceed L/4 or ¼ of actual main span. Assumes cantilever length/180 deflection with 220 lb point load (See Figure 1A and Figure 2).

4. Incising assumed for Douglas fir-larch, hem-fir, and spruce-pine-fir.

5. Design values based on northern species with no incising assumed.

6. Ledger shall be a minimum of 2x8 nominal. Where guards are required, outside joists and rim joists shall be a minimum of 2x8 nominal.

7. Joist length prescriptively limited to 18'-0" for footing design.

JOISTDETAILS

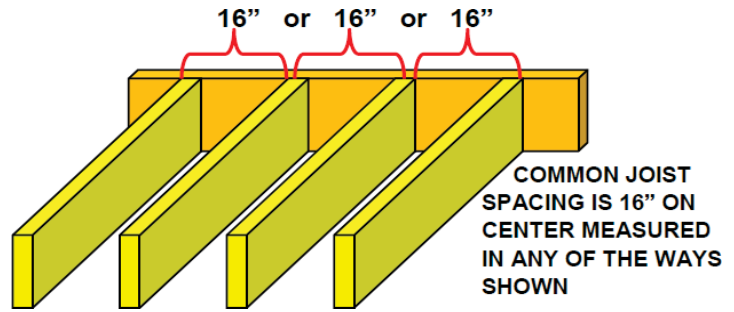
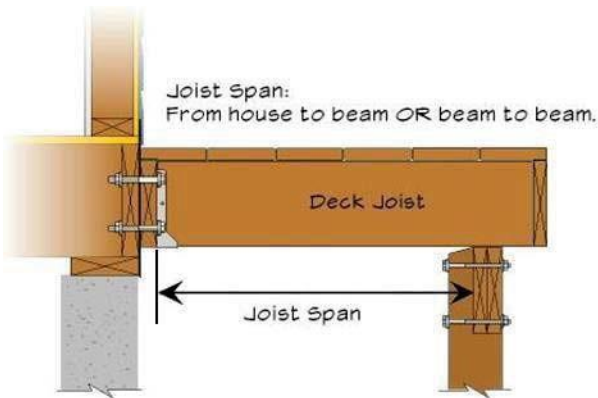

Joist spacing is determined by the type of decking used. 16" o.c. spacing must be used with 5/4 decking or when 2x6 or 2x4 decking is used at a 45° angle. 12" o.c. spacing required when 5/4 decking is used at a 45° angle.

WOOD DECKING

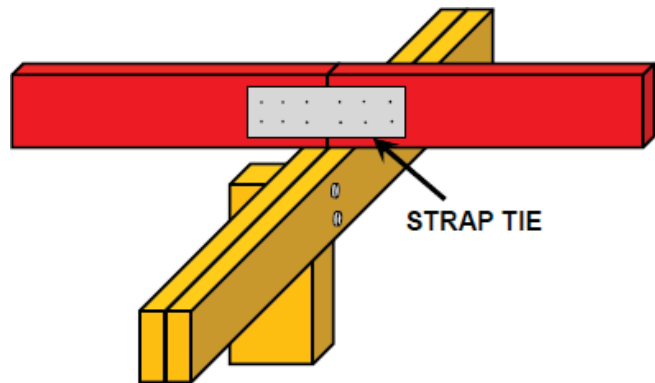
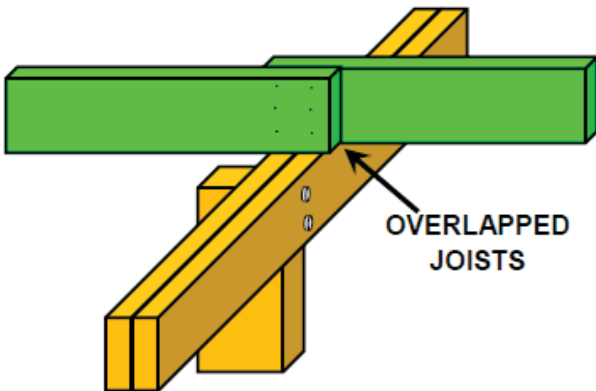
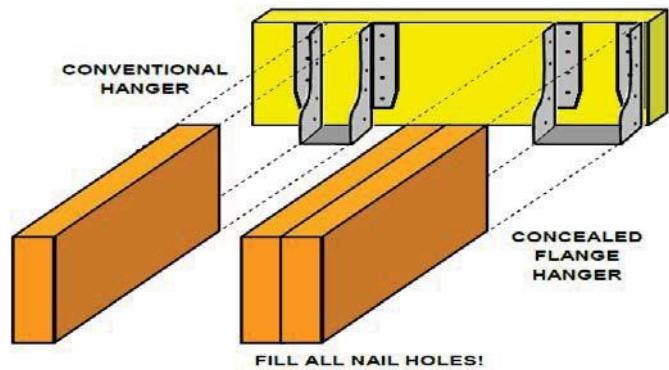

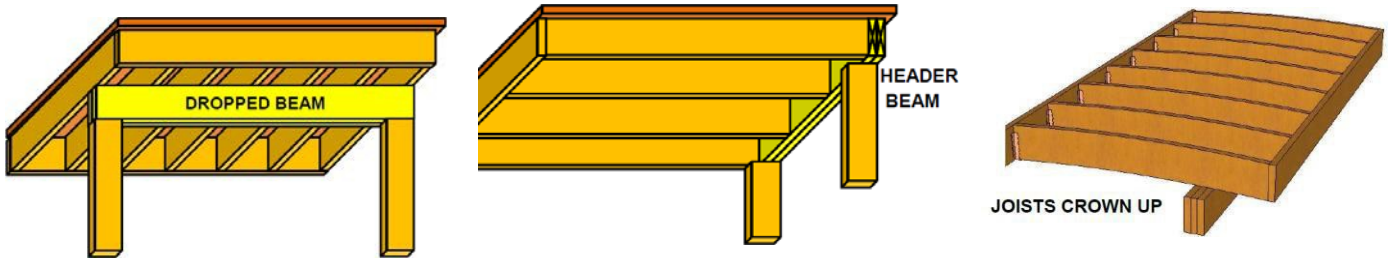

JOIST TO BEAM ATTACHMENTS

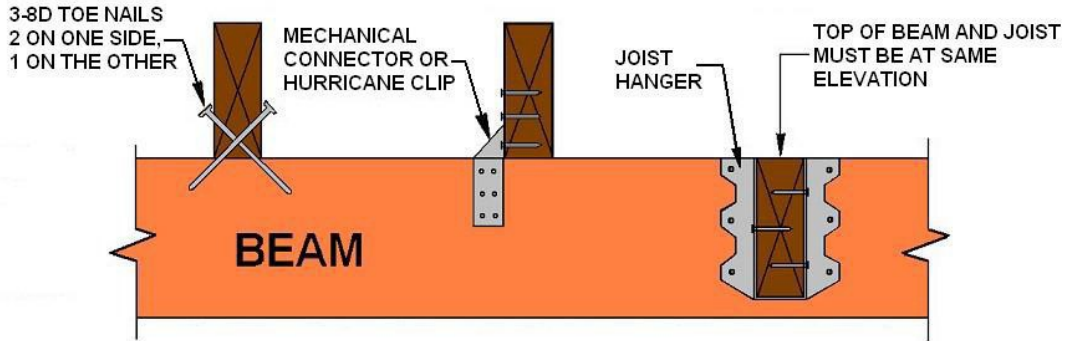

Joists must bear on a beam, ledger strip, or joist hangers. Joist hangers must be installed in accordance with the manufacturer's recommendations. **Fill all nail holes in joist hangers.**

RIM JOIST ATTACHED TO LEDGER WITH CONCEALED FLANGE HANGER

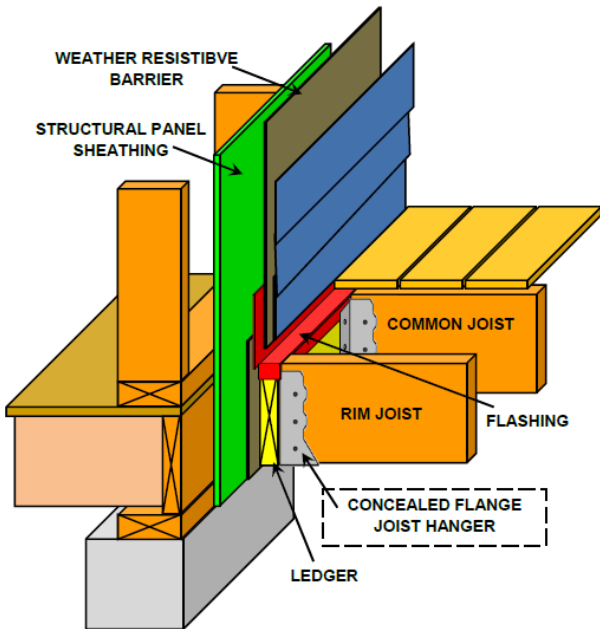

RIM JOIST ATTACHED TO LEDGER BY END NAILING - NOT ALLOWED

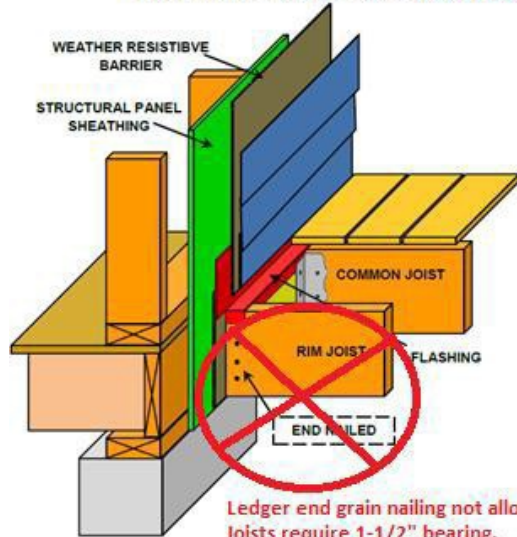

Ledger end grain nailing not allowed. Joists require 1-1/2" bearing. Use approved concealed flange hanger.

CANTILEVERS

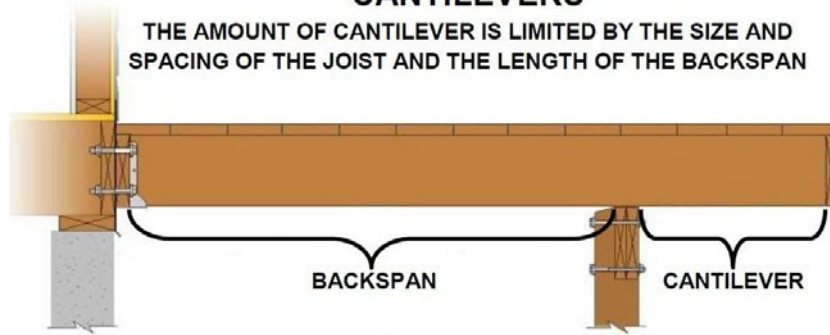

SPECIAL FLOORFRAMINGDETAILS

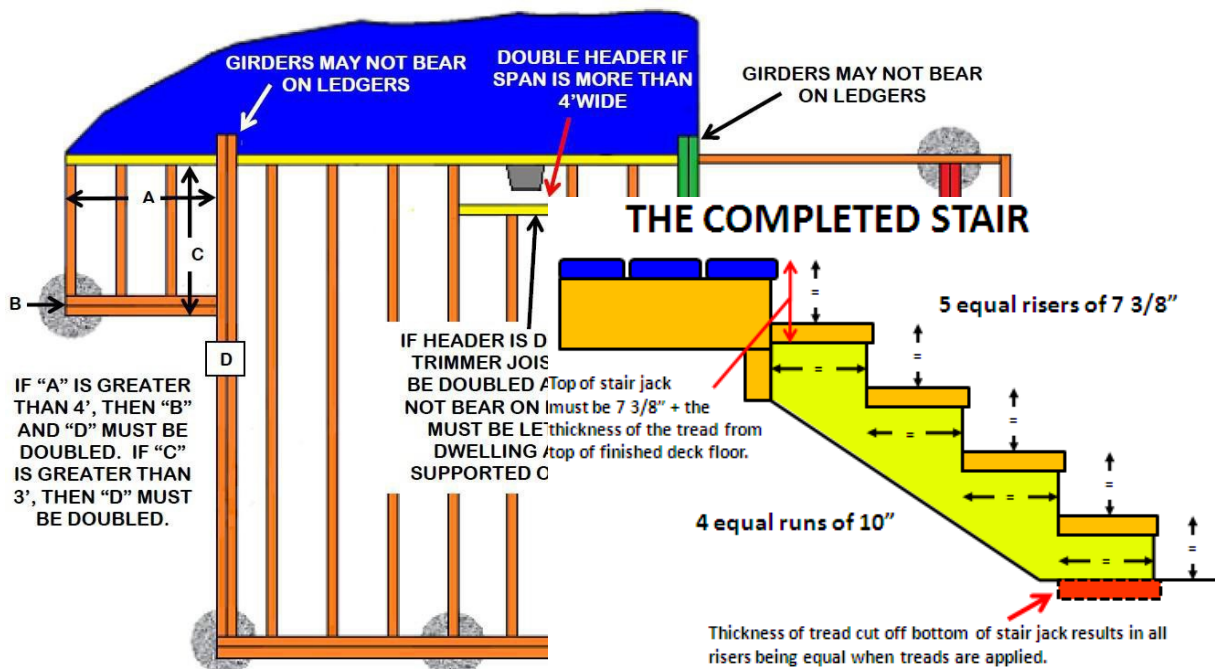
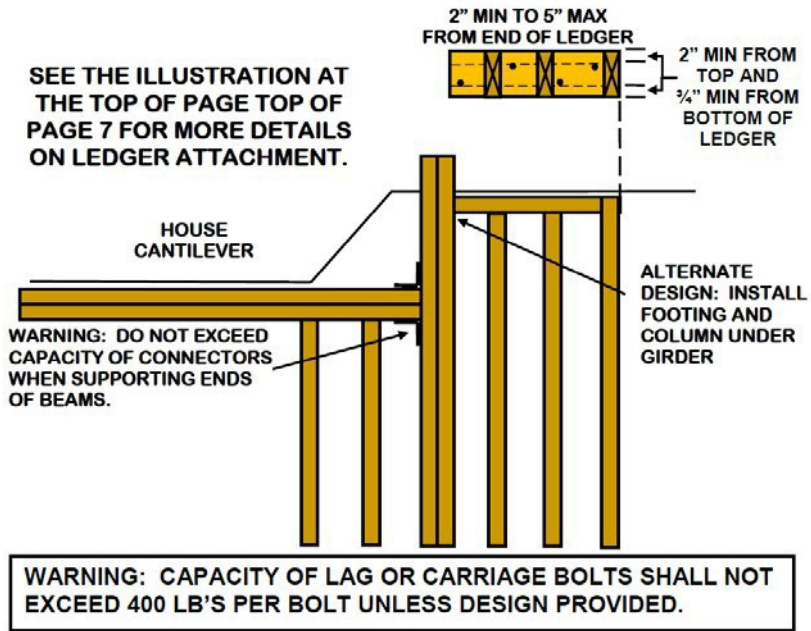

Stairs must have a maximum rise of $7 \frac{3}{4}$ inches and a minimum run of 10 inches measured as shown. The greatest riser height within any flight of stairs shall not exceed the smallest by more than $\frac{3}{8}$ inch. The greatest tread depth within any flight of stairs shall not exceed the smallest by more than $\frac{3}{8}$ inch. **Open risers are permitted provided that a 4" diameter sphere will not pass between the treads when stairs are over 30" above grade.**

Stairs must be a minimum of 36 inches wide above the handrail and 31½ inches below the handrail.

STAIR TERMINOLOGY

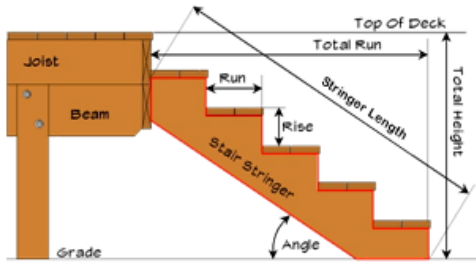

Stair Basics

- The maximum riser height is $7 \frac{3}{4}$ inches
- The minimum tread run is 10 inches
- Treads and risers should be approximately equal with the largest not exceeding the smallest by more than $\frac{3}{8}$ inch.

DETERMINING RISE/RUN

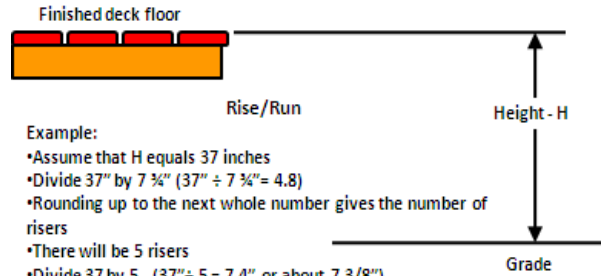

Example:

- Assume that H equals 37 inches
- Divide 37" by $7 \frac{3}{4}$ " ($37" \div 7 \frac{3}{4}" = 4.8$)
- Rounding up to the next whole number gives the number of risers
- There will be 5 risers
- Divide 37" by 5. ($37" \div 5 = 7.4"$ or about $7 \frac{3}{8}"$)
- Each riser will be $7 \frac{3}{8}"$
- For 5 risers there will be 4 treads
- Since each tread must be at least 10", the length of the stair from the face of the deck to the face of the bottom riser will be at least 40" ($10" \times 4 \text{ treads} = 40"$)

LAYING OUT STAIR JACKS

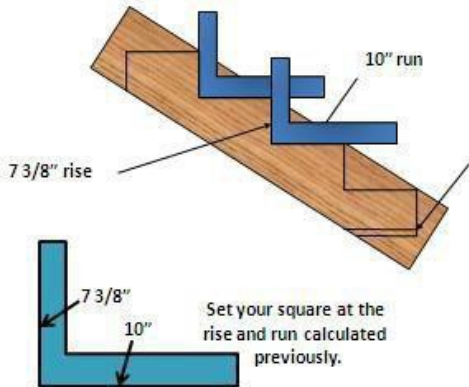

Cut an amount equal to the thickness of the tread from the bottom of the stair jack

THE COMPLETED STAIR

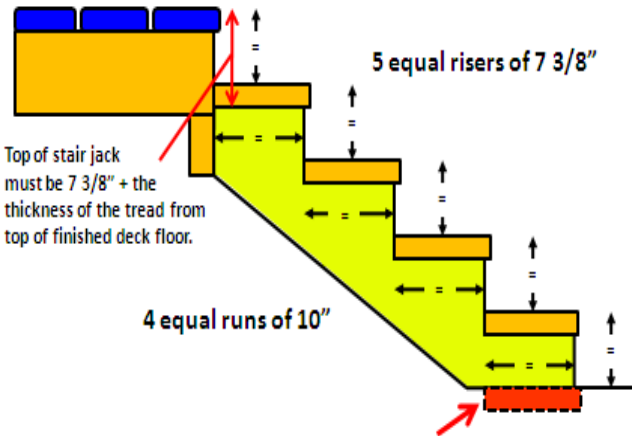

Thickness of tread cut off bottom of stair jack results in all risers being equal when treads are applied.

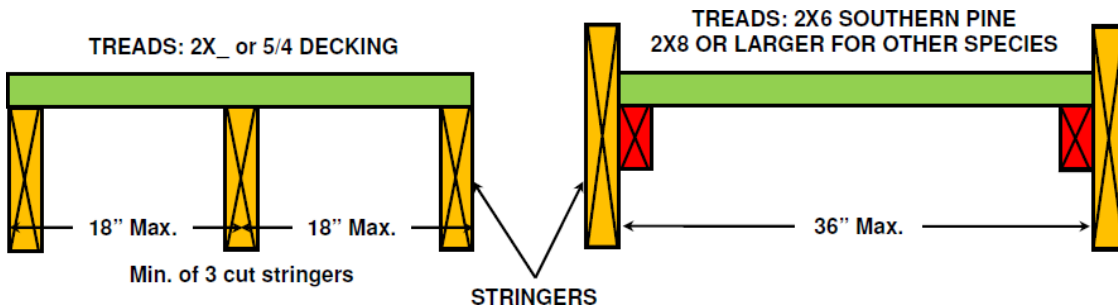

STAIR STRINGER SPANS

LANDINGS OR COLUMNS AND BEAMS MAY BE USED TO SHORTEN STRINGER SPANS

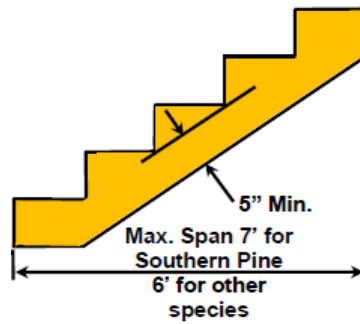

CUT STRINGER

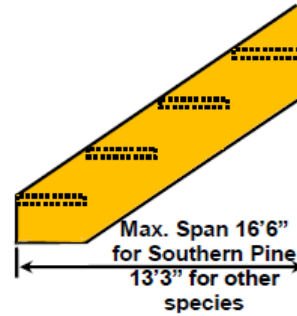

SOLID STRINGER

STAIR ATTACHMENTS

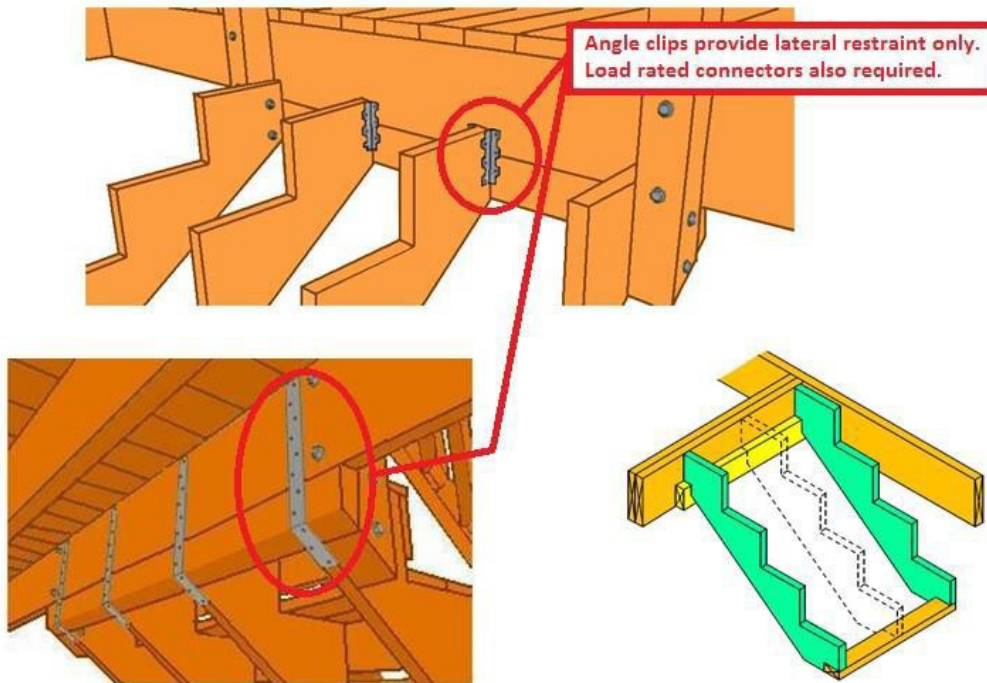

GUARDS AND HANDRAILS

Guards and handrails must be provided as shown on the following illustrations. Guards must continue down stairs where the stair is more than 30 inches above grade. The height of guards on stairs must be 34 inches minimum.

Handrails must be provided on at least one side when there are four or more risers. Handrails must have returns on each end or terminate in a newel post. Other handrail shapes having an equivalent gripping shape may be used with prior approval of the Building Department.

Handrails must be continuous for the entire length of the stairs and may not be interrupted by newel posts except at landings.

Handrails and guards must be designed to support a 200lb load applied in any direction at any point along the top of the guard or rail.

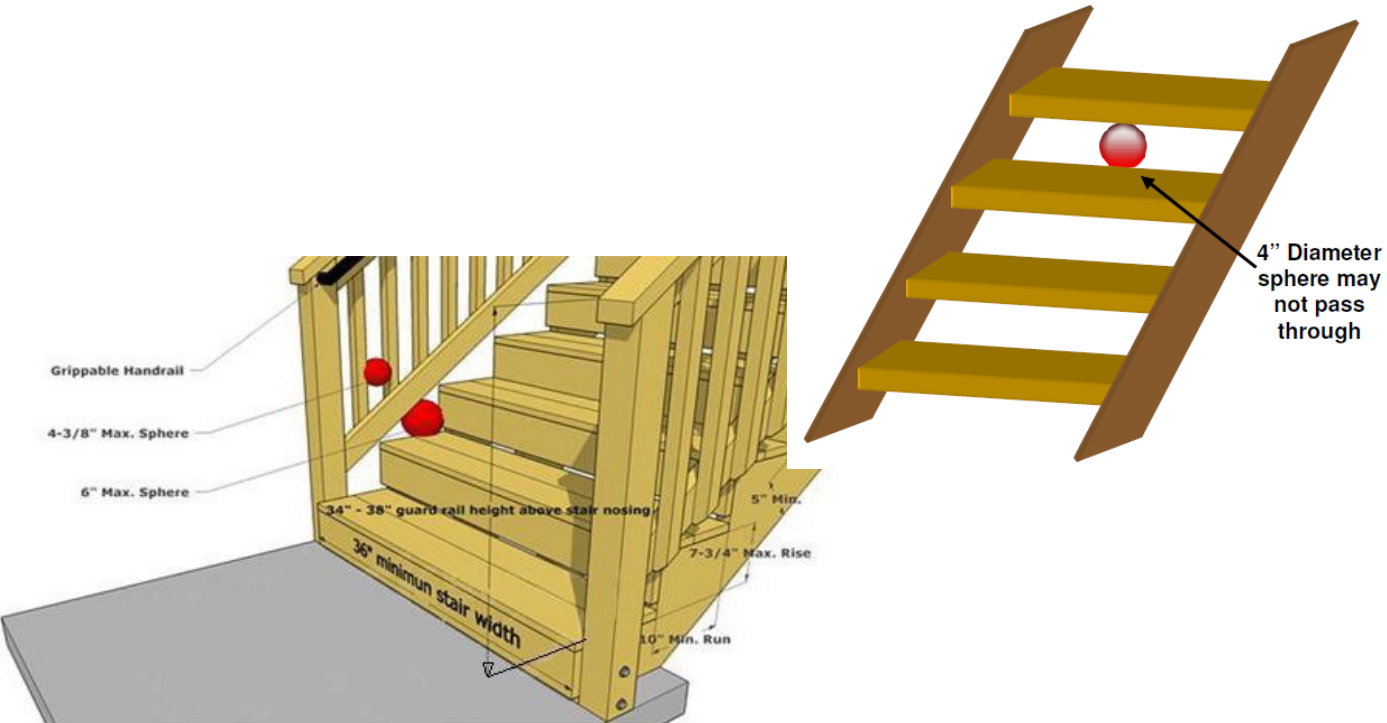

LANDING SHALL SPAN FULL WIDTH OF STAIRS & EXTEND A MINIMUM OF 36 INCHES IN THE DIRECTION OF TRAVEL.
STAIRS MUST BEAR ON STRUCTURAL MATERIAL (i.e. treated lumber, concrete, gravel) AND BE PERMANENTLY RESTRAINED FROM LATERAL MOVEMENT.

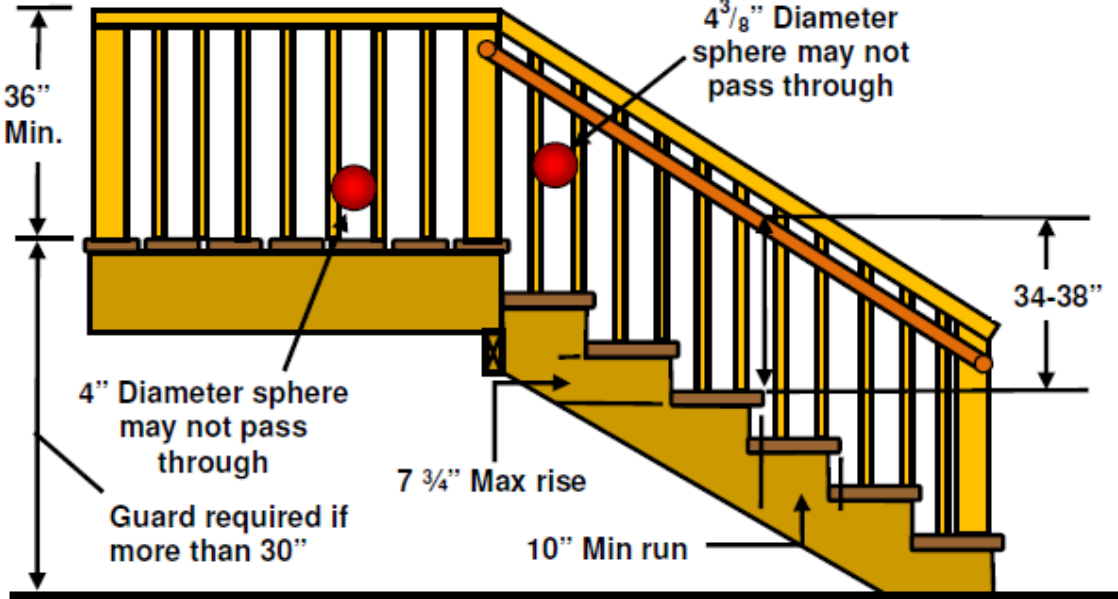

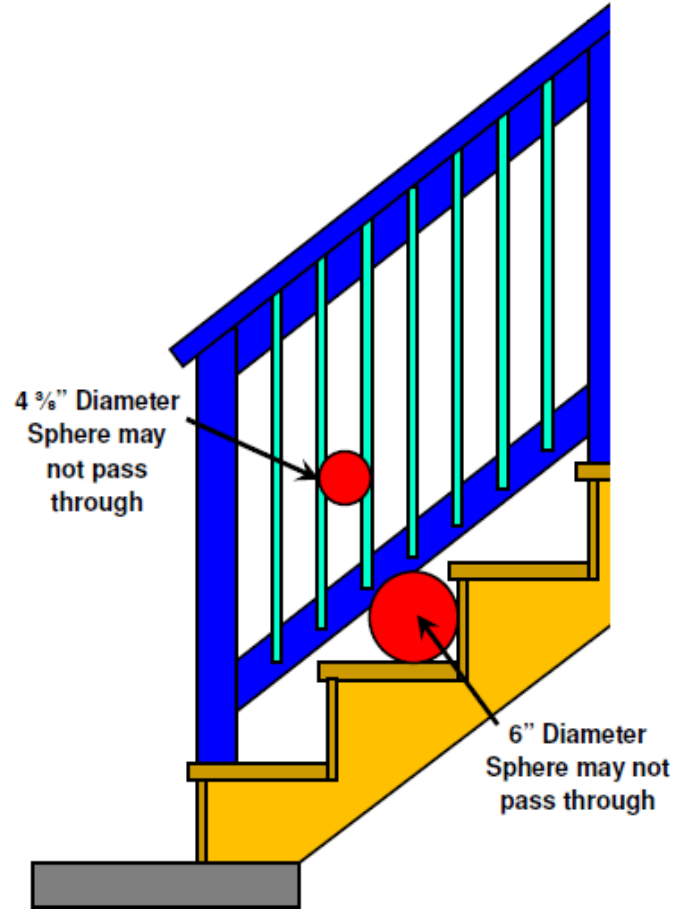
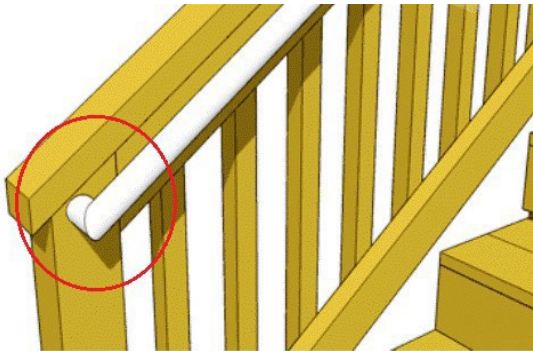

HANDRAILS MUST RETURN TO NEWEL POST AND BE CONTINUOUS WITHOUT INTERRUPTION FOR THE LENGTH OF THE FLIGHT INTERUPTION FOR THE LENGTH OF THE FLIGHT

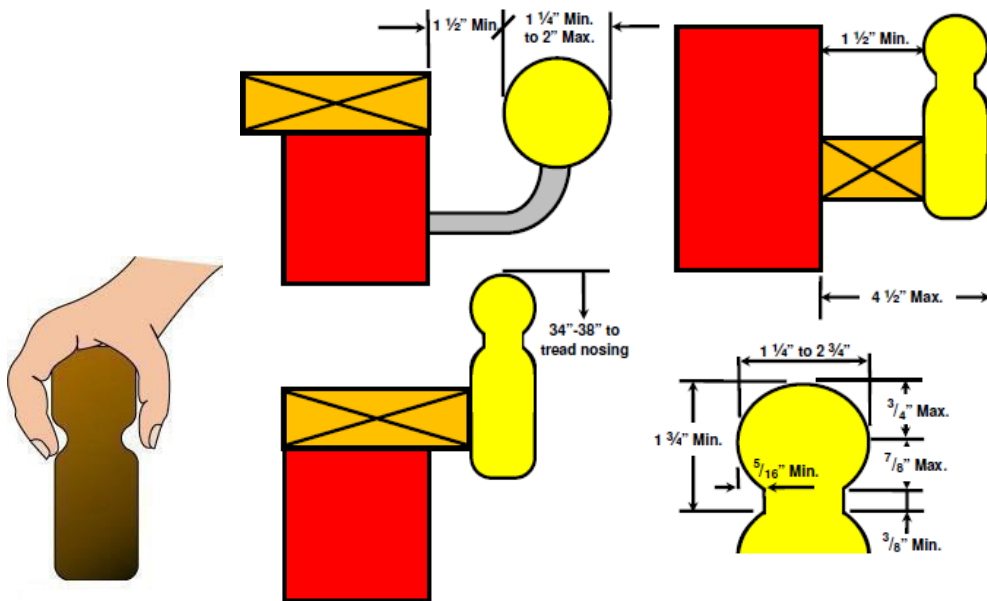

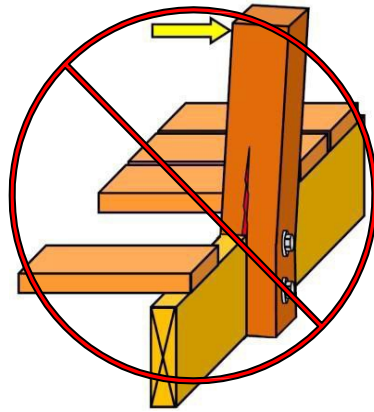
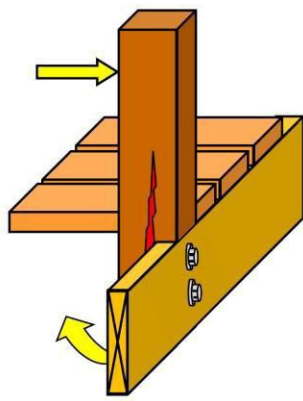

**AVOID NOTCHING
GUARD POSTS**

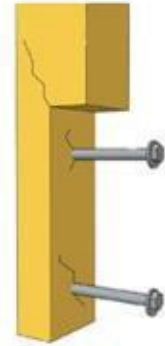

**BLOCKING MAY BE ADDED TO
STRENGTHEN POST ATTACHMENT**

**Examples of Devices that can be
used to resist horizontal loads**

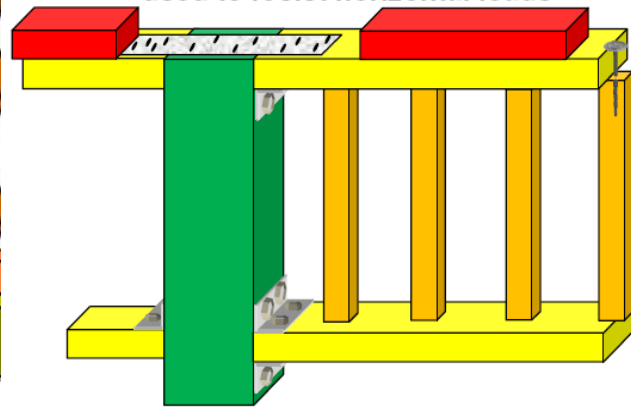
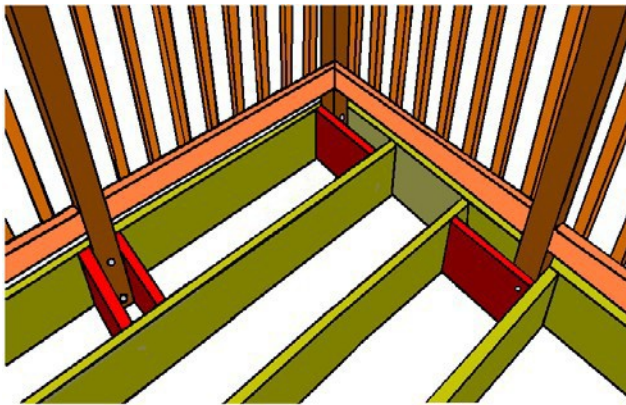

COMPOSITES AND OTHER DECK/RAILING PRODUCTS

Wood/plastic composites used for exterior deck boards, stair treads, handrails and guardrail systems must bear labels indicating compliance with ASTM D 7031 or a current ICC Evaluation Services Report must be made available.

Wood/plastic composites complying with ASTM D7031 must be installed in accordance with the manufacturer's written installation instructions.

Wood/plastic composites having an ICC ES Report must be installed in accordance with the manufacturer's installation instructions and the report.

READ THE INSTRUCTIONS AND THEIR REPORTS CAREFULLY. ALL PRODUCTS HAVE SPECIFIC REQUIREMENTS FOR STAIR TREADS. SOME ARE LIMITED TO INSTALLATION PERPENDICULAR TO JOISTS ONLY.

PRODUCTS MADE OF ALUMINUM, STEEL, GLASS, OR ANY OTHER MAN MADE PRODUCT MAY BE USED IF THE MANUFACTURER HAS A RESEARCH REPORT FROM THE INTERNATIONAL CODE COUNCIL AND THE PRODUCT IS INSTALLED IN STRICT ACCORDANCE WITH THAT REPORT OR SITE SPECIFIC ENGINEERING IS PROVIDED.

Framing Fasteners

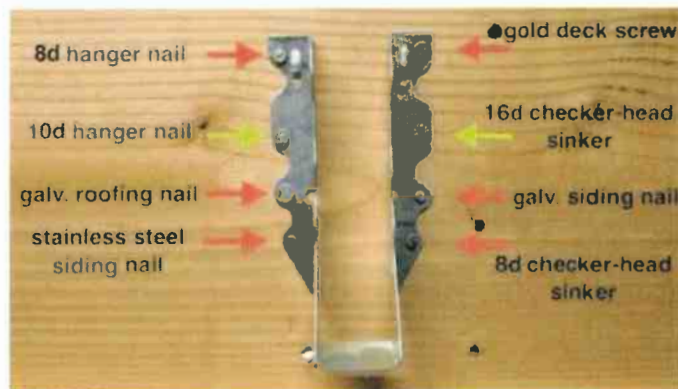
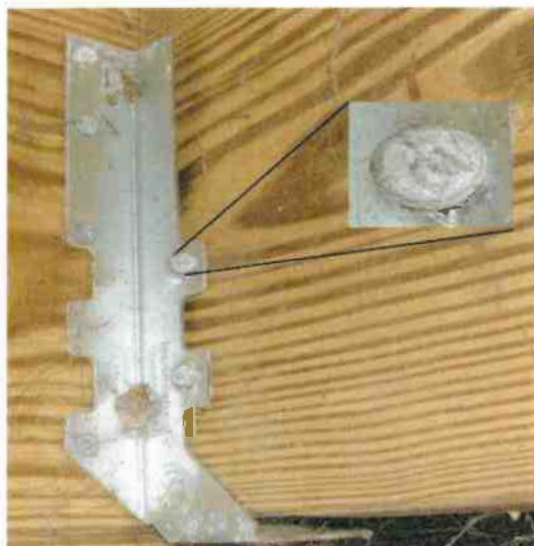

The red arrows are not accepted



GRK Screws have been approved to use in hangers

Deck Ledger Fastener

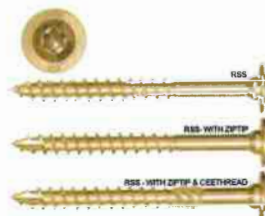

Railing Post Attachment



Concrete attachment

