



AGENDA FOR THE WORK SESSION AND THE  
REGULAR MEETING OF THE  
ALBERT LEA CITY COUNCIL – June 08, 2026  
WORK SESSION – 5:30 PM – REGULAR MEETING – 7:00 PM

---

**WORK SESSION – 5:30 PM**

- I. MINNESOTA STATE STRIKE TEAM ASSET – FIRE CHIEF LASKOWSKE TO PRESENT
- II. REVIEW COUNCIL MEETING AGENDA OF JUNE 08, 2026

**REGULAR MEETING – 7:00 PM**

- I. **CALL TO ORDER AND ROLL CALL**
- II. **PLEDGE OF ALLEGIANCE**
- III. **CEREMONIAL ITEMS**
- IV. **PUBLIC FORUM**
- V. **CONSENT AND APPROVAL OF AGENDA**
  - A. Approve Minutes of the May 26, 2026 Regular Council Meeting
  - B. Approve Minutes of the May 26, 2026 Work Session
  - C. License & Permits
  - D. Resolution Approving Plans and Specifications and Ordering Advertisement – Airport Snow Removal Equipment Building Door – Job 2608
- VI. **PETITIONS, REQUESTS AND COMMUNICATIONS**
- VII. **UNFINISHED BUSINESS**
  - A. Ordinance 26-156 Amending Chapter 8 – Article II. – Animal Control (2<sup>nd</sup> Reading)
  - B. Resolution Permitting Publication of Ordinance 26-156 Summary - Chapter 8 - Animals Article II. - Animal Control
- VIII. **NEW BUSINESS**
  - A. Resolution Approving Final Plat of Battleson Renchin Addition



AGENDA FOR THE WORK SESSION AND THE  
REGULAR MEETING OF THE  
ALBERT LEA CITY COUNCIL – June 08, 2026  
WORK SESSION – 5:30 PM – REGULAR MEETING – 7:00 PM

---

- B. Ordinance Amending Zoning and the Landuse Map From Single-Family Residence (R-1) to Industrial District (I-2) for Outlot A of Battleson Renchin Addition (1<sup>st</sup> Reading)
- C. Resolution Approving Conditional Use Permit for Bridge #R1144 Replacement (Songbird Trail)
- D. Resolution Approving the State of Minnesota Department of Employment and Economic Development (DEED) Cleanup Grant Agreement No. 281697 for the Family Housing Development Project (Tapestry) – Job 2611
- E. Resolution Calling a Public Hearing for Declaring No Public Purpose and Waiving Planning Commission Review (Portion of Morin Park) – Job 2612
- F. Resolution Authorizing Execution of MNDNR Myre-Big Island State Park Sewer Collection System Design & Service Cooperative Agreement – Job 2619
- G. Resolution Authorizing Execution of MNDNR Myre-Big Island State Park Sewer Collection System Joint Powers Agreement – Job 2619
- H. Resolution Determining the Revenues Raised by the City's 0.5% Sales and Use Tax Will Meet or Exceed the Authorized Amount on or Before September 30, 2026, and the Tax Shall Expire on that Date
- I. Resolution Providing for the Issuance and Sale of \$5,310,000 General Obligation Bonds, Series 2026A
- J. Resolution Designating 2-Hour Parking on the South Side of College Street From S. Broadway Avenue (TH-65 to Newton Avenue – 2026 Misc. 181
- K. Resolution Accepting Donations – Friends of the Library
- L. Resolution Acknowledging the Establishment of the Albert Lea Port Authority Levy
- M. Resolution Approving Amendments to the Port Authority By-Laws
- N. Resolution Approving Increase in Building Maintenance Staff Hours of Employment

**IX. MAYOR AND COUNCIL REPORTS**

**X. CITY MANAGER REPORT**

**XI. APPROVAL OF CLAIMS**

- A. Resolution Approving Claims
  - (1) Presentation of Claims Over \$25,000



AGENDA FOR THE WORK SESSION AND THE  
REGULAR MEETING OF THE  
ALBERT LEA CITY COUNCIL – June 08, 2026  
WORK SESSION – 5:30 PM – REGULAR MEETING – 7:00 PM

---

XII. ADJOURNMENT

**Disclaimer: This agenda has been prepared to provide information regarding an upcoming meeting of the City Council of the City of Albert Lea. This document does not claim to be complete and is subject to change**



City Manager Report to Council  
221 East Clark Street, Albert Lea, MN 56007  
(507) 377-4330 – [info@ci.albertlea.mn.us](mailto:info@ci.albertlea.mn.us)

---

**To: Mayor and City Council**  
**From: City Manager**  
**Date: June 08, 2026**  
**Re: June 08, 2026 City Council Meeting**

---

V. CONSENT AND APPROVAL OF AGENDA

C. Licenses & Permits –

**MOBILE VENDOR**

*Kee Kafe, LLC DBA Bummys BBQ – Kiester, MN*

*Ruthies Ice Cream Sandwiches*

*Nels Diner #1*

*Nels Diner #2*

*B-Lo Zero Sno Cones*

*Gourmet Minne Donuts*

*Golden Hour Dirty Soda*

**TREE TRIMMER**

*Larson Services LLC*

*From the Ground Up – Owatonna, MN*

*Attig Tree Service – Glenville, MN*

*O’Connell Tree Service – Hollandale, MN*

*Johnson Construction & Tree Service LLC – Austin, MN*

*Pat’s Tree Service LLC – Lyle, MN*

*Coles Complete Tree Care – Austin, MN*

**GARBAGE HAULER**

*Thompson Sanitation Inc. – Clarks Grove, MN*

**ON-SALE LIQUOR LICENSE**

*LV Petroleum, LLC – Las Vegas, NV (Purchased former Trails Travel Center)*

**ON-SALE LIQUOR LICENSE – 3.2%**

*Jake’s Pizza*

**OFF-SALE LIQUOR LICENSE – 3.2%**

*Hy-Vee Grocery*

*Harold's Bar*

**SIGN HANGER**

*Indigo Signworks, Inc. DBA Indigo Signs – Alexandria, MN*

*Winkels Electric, Inc. – Rochester, MN*

*Precision Signs Service & Install, LLC – Austin, MN*

**MASSAGE THERAPIST**

*Rest & Restore Massage Studio – Brooke Leedom*

*Eleventh Ray Healing LLC – Rachel R. Thompson*

*Emily Grace Toresdahl – Allure Salon and Spa*

- D. Resolution Approving Plans and Specifications and Ordering Advertisement – Airport Snow Removal Equipment Building Door – Job 2608 – *On January 26, 2026 a grant was approved to prepare plans and specifications to modify the doors of the snow removal equipment (SRE) building to replace two smaller doors with a larger door.*

*Bolton and Menk Inc. has prepared the plans and specifications. This resolution authorizes the bidding of the project. Once the bids are received another 70 percent state and 30 percent local grant will be written for the construction of the work.*

*Staff recommends approving the plans and specifications and authorization of bidding the project.*

See attached resolution.

VI. PETITIONS, REQUESTS AND COMMUNICATIONS

VII. UNFINISHED BUSINESS

- A. Ordinance Amending Chapter 8 – Article II. – Animal Control (2<sup>nd</sup> Reading) – *The proposed amendments to the Animal Control ordinance update and modernize the city's approach to responsible pet ownership, public safety, and community expectations. Several sections of the existing ordinance were outdated or no longer aligned with current best practices, enforcement needs, or community concerns. The revisions aim to clarify definitions, strengthen nuisance and safety provisions,*

*and ensure consistent, enforceable standards for both pet owners and animal control staff. Key amendments are outlined in the summary included in the council packet.*

See attached ordinance.

- B. Resolution Approving Publication Summary – Ordinance 26-156 - Ordinance  
*Summaries may be published if they reasonably inform the public of the effect and intent of the Ordinance. Summaries fulfill all legal requirements as if the entire summarized matter had been published, and also direct the public on how to obtain the complete Ordinance.*

See attached resolution.

#### VIII. NEW BUSINESS

- A. Resolution Approving Final Plat of Battleson Renchin Addition –The Planning Commission held a public hearing on June 2, 2026 to review Preliminary Plat of Battleson Renchin Addition for compliance with Chapter 38 Subdivisions.

*The purpose of the plat is to subdivide a smaller 4-acre parcel (outlot A) in order to facilitate the eventual sale to Vortex Cold Storage for a future expansion. The property is currently zoned R-1 or single family residential, however, an application to re-zone outlot A from residential to industrial was submitted in conjunction with the plat application.*

*Planning Commission recommends approval of the final plat of Battleson Renchin Addition.*

See attached resolution.

- B. Ordinance Amending Zoning and the Landuse Map From Single-Family Residence (R-1) to Industrial District (I-2) for Outlot A of Battleson Renchin Addition (1<sup>st</sup> Reading) - Jon Battleson and Krissandra Renchin applied to re-zone outlot A of Battleson Renchin Addition from Single Family Residence (R-1) to Industrial District (I-2) in order to accommodate the eventual sale and future expansion with Vortex Cold Storage. The property directly abutting to the south (also owned by Vortex Cold Storage) and the remaining Port Authority No. 3 or the ALEDA Jobs Park is currently zoned Industrial District which eliminates the concern for spot zoning.

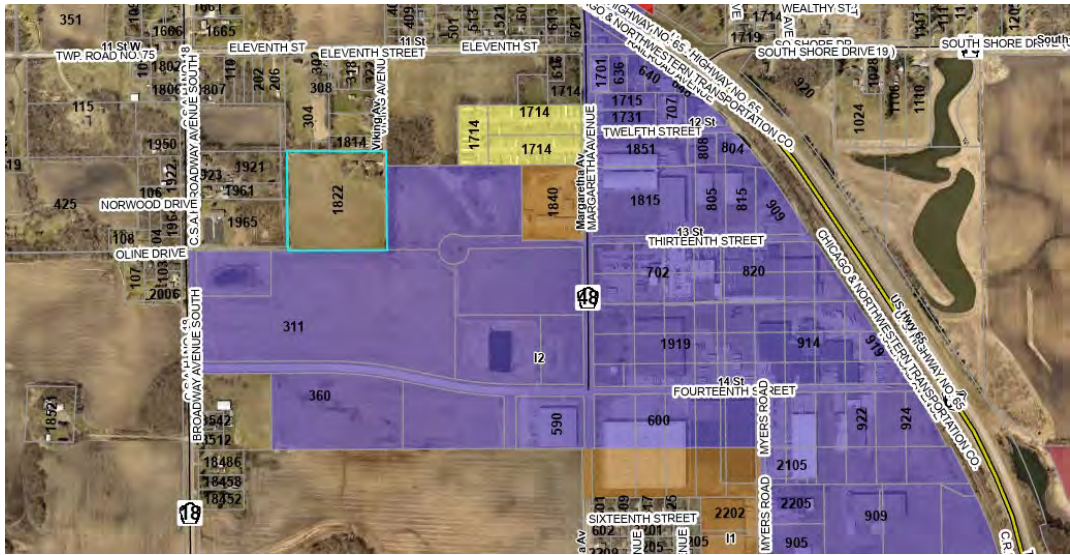

*The 2040 Comprehensive Land Use Plan identifies this area as residential in nature. However, as the ALEDA Jobs Park has filled over time, the industrial users have continued to grow and expand while housing in this area has not. Staff believes the market has demonstrated this area is better suited for industrial rather than housing given its close proximity to other recent and successful industrial users and as such the Comprehensive Land Use Plan should be amended to reflect the actual development trends once the re-zoning is approved.*

*The Planning Commission held a public hearing on June 2, 2026 and after considering the staff report in addition to public testimony the commission recommends approval based on the following:*

- 1. Rezoning the property will not have an adverse effect on existing and adjacent properties as the area is largely industrial.*
- 2. The use meets the general zoning requirements of the sounding Industrial District.*

*Planning Commission recommends approval.*

See attached ordinance.

- C. Resolution Approving Conditional Use Permit for Bridge #1144 Replacement (Songbird Trail) - The City of Albert Lea in partnership with Freeborn County applied for a conditional use permit for pedestrian bridge replacement in the F-1 Floodway

*district. The bridge is situated within the former Union Pacific Railroad Corridor, is part of the overall Songbird Trail development and needs replacement in order to correct safety issues.*

*The proposed bridge meets the conditions of the F-1 Floodway District by not impacting public waters or wetlands, having property erosion and sediment prevention plans and by implementing a design that will not change current flow characteristic of the channel from what is existing. In addition, while the bridge itself is within the F-1 Floodway District, most of the staging and construction will take place within the UP Rail Corridor which is outside of the F-1 Floodway District.*

*Lastly, the proposed bridge is consistent with the 2030 Comprehensive Plan which designates Songbird Trail as a future trail network.*

*Planning Commission recommends approval of the Conditional Use permit with conditions that a stormwater pollution prevention plan (SWPPP) be kept on file in part of the CUP approval.*

See attached resolution.

- D. Resolution Approving the State of Minnesota Department of Employment and Economic Development (DEED) Cleanup Grant Agreement No. 281697 for the Family Housing Development Project (Tapestry) – Job 2611 – *Attached for Council review and approval is a resolution to execute the State of Minnesota Department of Employment and Economic Development (DEED) Cleanup Grant Agreement for the Family Housing Development Project (Tapestry). The grant can fund approximately 75 percent of eligible work with a total reimbursement amount not to exceed \$267,487. The project involves excavation and disposal of contaminated soil, backfilling, and grading of onsite clean soil throughout the project area for development of a Family Housing Development Project (Tapestry). Engineering is recommending entering into the agreement.*

See attached resolution.

- E. Resolution Calling a Public Hearing for Declaring No Public Purpose and Waiving Planning Commission Review (Portion of Morin Park) – Job 2612 - *This resolution would call a public hearing for July 13, 2026 at 7:00 p.m. for the purpose of*

*authorizing the sale to the Minnesota Department of Transportation of a small piece of the southwest corner of Morin Park that is currently owned by the City of Albert Lea, but for which a permanent easement has been granted to the Minnesota Department of Transportation for existing sidewalk, Americans with Disabilities Act, and roadway. No additional property, aside from what has already been granted a permanent easement and is currently being used for state highway and sidewalk purposes would be sold with this transfer.*

*This sale is in conjunction with sidewalk and ADA improvements that MnDOT will be performing along W. Main Street and S. Broadway Avenue (TH 13 and 65) as part of Job No. 2612. Staff recommends approval.*

See attached resolution.

- F. Resolution Authorizing Execution of MNDNR Myre-Big Island State Park Sewer Collection System Design & Service Cooperative Agreement – Job 2619 – Staff has been working with the DNR since 2017 to get Myre-Big Island State Park connected to City sewer and abandon their current pond wastewater system. This project was delayed first because of funding, and then because of Indian burial grounds that required rerouting.

*The project will involve the DNR constructing a collection system and a lift station at the park and then constructing a forcemain from the state park along the state park road (780<sup>th</sup> Avenue) to a City manhole located near the intersection of East Main Street and 780<sup>th</sup> Avenue.*

*Highlights include:*

- *A 25-year sewer cooperative agreement with 5-year renewals thereafter*
- *City agrees to accept their sewage and charge the rates shown in City fee schedule*
- *DNR base fee would be based on a 2-inch meter size*
- *DNR will be charged a consumption fee based on the lift station meter monthly total. They would install a meter that the City meter reader can read electronically when completing the monthly meter readings.*
- *DNR will pay one-time sewer connection fee of \$7,000. This is based off of a \$1,000 sewer connection fee per building, there are 7 buildings onsite.*

*The resolution authorizes the Mayor and City Manager to sign the agreement. Engineering is recommending entering into the agreement.*

See attached resolution.

- G. Resolution Authorizing Execution of MNDNR Myre-Big Island State Park Sewer Collection System Joint Powers Agreement – Job 2619 – *This item authorizes the Mayor and City Manager to sign a joint powers agreement with the MNDNR regarding one call locates and emergency response services for the forcemain from the Myre-Big Island State Park to the City sanitary sewer system.*

*The project involves the DNR building a collection system and a lift station at the park and then constructing a forcemain from the state park along the state park road (780<sup>th</sup> Avenue) to a City manhole located near the intersection of East Main Street and 780<sup>th</sup> Avenue.*

*Highlights include:*

- *The City will provide locates on this forcemain for the MNDNR and will bill MNDNR monthly for this service. Rates will be based on the City fee schedule.*
- *If requested the City would perform emergency repairs on the DNR system and bill them for those services. This would be for emergencies only and not include routine maintenance.*

*The resolution authorizes the Mayor and City Manager to sign the agreement. Engineering is recommending entering into the agreement.*

See attached resolution.

- H. Resolution Determining the Revenues Raised by the City's 0.5% Sales and Use Tax Will Meet or Exceed the Authorized Amount on or Before September 30, 2026, and the Tax Shall Expire on that Date – *The watershed will reach the \$30 million of sales tax received in July or August. This resolution will stop the additional .5% sales tax at the end of September as required by Minnesota sales tax provisions. Any funds received prior to September 30, 2026 over the \$30,000,000 will be retained by the City and placed in the City's General Fund.*

See attached resolution.

- I. Resolution Providing for the Issuance and Sale of \$5,310,000 General Obligation Bonds, Series 2026A – *Per the City Charter, the City of Albert Lea has the authority to issue General Obligation Improvement Bonds to provide financing for public improvement projects undertaken by the City. Staff recommends the sizing of the bond to be \$5,310,000 to finance the bonding costs, assessments, water portion and the levy funded portions of the projects as estimated below. The term of the bond is 15 years. The bonds will be sold on July 13, 2026. The project amounts are summarized below.*

	Assessments	Water Fund	Levy	Bonding Costs	Total
Job 2517 - Valley Avenue and Marshall Street	\$ 494,515	\$ 625,005	\$ 285,000	\$ 43,985	\$ 1,448,505
Job 2601 - 2026 Neighborhood Project	\$ 760,775	\$ -	\$ 892,204	\$ 51,766	\$ 1,704,745
Job 2602 - 2026 State Aid Street Overlay	\$ 51,671	\$ -	\$ -	\$ 1,618	\$ 53,289
Job 2603 - St Mary Avenue and 14th Strret	\$ 299,694	\$ 331,761	\$ 420,689	\$ 32,950	\$ 1,085,094
Job 2604 Sorensen Road Watermain Replacement	\$ -	\$ 987,443	\$ -	\$ 30,924	\$ 1,018,367
	\$ 1,606,655	\$ 1,944,209	\$ 1,597,893	\$ 161,243	\$ 5,310,000

See attached resolution.

- J. Resolution Designating 2-Hour Parking on the South Side of College Street From South Broadway Avenue (TH-65) to Newton Avenue – *This resolution would (1) designate the on-street parking along the south side of College Street from South Broadway Avenue (TH-65) to Newton Avenue as two-hour parking from 8:00 a.m. to 5:00 p.m., and (2) authorize a study of the intersection of E. College Street and Newton Avenue for the evaluation and possible implementation of pedestrian crossing safety improvements. Options proposed for consideration include a Rectangular Rapid Flashing Beacon (RRFB), additional enhanced markings and/or signage, and curb bumpouts.*

*The parking change is primarily at the request of Freeborn County to better serve the public utilizing the Courthouse and surrounding businesses. The pedestrian safety improvements are being proposed to address safety concerns for County employees that park in the municipal parking northeast of this intersection and cross here to access the Courthouse. A consultant will be hired to evaluate the intersection, and provide alternatives and cost estimates. Staff recommends approval.*

See attached resolution.

- K. Resolution Accepting Donations – Friends of the Library – *The Friends of the Albert Lea Public Library raise non-profit funds for programs and equipment not covered by the general library budget. The Friends of the Albert Lea Public Library raise the funds through the Fountain Lake Bookstore, two book sales throughout the year, membership fees, and general donations. From January through May 2026, the Friends of the Albert Lea Public Library donated a total of \$1,443.08 to the Albert Lea Public Library. The funds were used for the programs listed on the included sheet. Without the generous donations from the Friends of the Albert Lea Public Library, many of the library’s programs would not be possible.*

See attached resolution.

- L. Resolution Acknowledging the Establishment of a Port Authority Levy – *The Port Authority already has the legal authority to establish a levy without Council approval. This is just acknowledging they are setting up the levy and may potentially use the levy in their 2027 budget. The real goal is to establish funding for capital projects such as a new industrial park or warehousing. The amount they can levy is 0.01813% of total valuation within their district (city boundaries). This is about \$300,000 annually excluding eligible general obligation debt payments. A \$250,000 valued residential house with homestead would pay approximately \$35-40 annually for the full levy amount. Again, this is not expected without a significant project, however the council should know the potential impact.*

See attached resolution.

- M. Resolution Accepting and Adopting Port Authority By-Laws – *The Port Authority wants to change its by-laws so that we can continue to have members who are connected to development such as private utilities, banking, industrial management and more. Sometimes those in positions of knowledge or interest in economic development do not reside in Albert Lea city limits. This change reflects that and some of the changes made by the City Council.*

See attached resolution.

- N. Resolution Approving Increase in Building Maintenance Staff Hours of Employment – *The resolution would authorize the City Manager to change the status of one employee from part-time to full-time. There are needs that have to be met and in one*

*way or another the city is going to be faced with costs to meet those needs. Changing the status of an existing employee at this time seems a better fit for the needs of certain city properties over the next 18 months. The cost is \$26,700 annually as of 2026 salary and benefits. However, the 2026 total budget impact is non-existent given we are unable to hire a GIS Technician in 2026. The impact is departmental budget in 2026 and long-term impact starting in 2027.*

See attached resolution.

XI. APPROVAL OF CLAIMS

A. Resolution Approving Claims – The attached resolution directs the Mayor and City Treasurer to issue the payment of claims as presented in the Detail of Claims report.

(1). Large Claims Over \$25,000 – When applicable, staff will present and display any claims over \$25,000 for the public’s viewing, transparency and education.

**REGULAR COUNCIL MEETING  
CITY COUNCIL CHAMBERS, CITY OF ALBERT LEA  
May 26, 2026 – 7:00 P.M.**

**PRESENT:** Mayor Rich Murray, Councilors Rachel Christensen, Larry Baker, Ted Herman, Reid Olson, Keith Van Beek, Brian Anderson, City Manager Ian Rigg, Civil Engineer Chris Lowe, City Attorney Joel Holstad of Lakes National Law LLP, and City Clerk Daphney Maras.

**ABSENT:** Public Works Director Steve Jahnke

**ADDITIONAL STAFF PRESENT:** Chief of Police Darren Hanson, Lieutenant, City Planner Megan Boeck

**CALL TO ORDER AND ROLL CALL** - Mayor Murray called the meeting to order at 7:00 PM. City Clerk Maras administered roll call.

**PLEDGE OF ALLEGIANCE** - Mayor Murray asked all in attendance to stand and recite the Pledge of Allegiance.

**CEREMONIAL ITEMS**

A. Mayor Murray read aloud the Proclamation Declaring June 4, 2026 as Day-Breakers Kiwanis Day.

**PUBLIC FORUM**

Dave Karge spoke of his opposition to lifting the dog/cat limit.

**CONSENT AND APPROVAL OF AGENDA**

- A. Approve Minutes of the May 11, 2026 Regular Council Meeting
- B. Approve Minutes of the May 11, 2026 Work Session
- C. License & Permits
- D. Resolution Approving Purchase of Parks Department Bucket Truck Chassis

Motion made by Councilor Baker to approve the consent agenda with the amendment to include adding the Moose Lodge to serve alcohol at Hayek Field for the adult baseball summer season 2026, seconded by Councilor Anderson. On roll call vote, the following councilors voted in favor of said motion: Christensen, Baker, Herman, Olson, Van Beek, Anderson, and Mayor Murray. Mayor Murray declared the motion passed.

(See Secretary's Original Resolution 26-090  
(Included with these minutes))

**PETITIONS, REQUESTS, AND COMMUNICATIONS** - None

**UNFINISHED BUSINESS** - None

**NEW BUSINESS**

**A. Resolution 26-091 Accepting Bid and Awarding Contract for the Front Street Bridge No. 24514 Rehabilitation Project (Job 2605)**

Engineering and Erickson Engineering has reviewed the bids opened Tuesday, May 19, 2026 for the Front Street Bridge No. 24514 Rehabilitation project.

The project involves pier repairs to the Front Street bridge. The work involved is not typical work which is reflected in the number of bids received, only one, and the amount of the bid. Finding a comparable project was also difficult which is also reflected in the engineers estimate.

Engineering is recommending accepting the low bid and awarding the contract for \$381,339.60 to PCIRoads LLC of Maple Grove, Minnesota. The Engineer's estimate was \$328,230.00. The bid abstract is attached. The City will be using its state aid funds on this project.

Motion made by Councilor Christensen to approve. Seconded by Councilor Van Beek. On roll call vote, the following councilors voted in favor of said motion: Christensen, Baker, Herman, Olson, Van Beek, Anderson, and Mayor Murray. Mayor Murray declared the motion passed.

(See Secretary's Original Resolution 26-091  
(Included with these minutes)

**B. Resolution 26-092 Accepting Bid and Awarding Contract for the WWTP Fiberglass Aeration Tank Covers & Ventilation Stacks Rehabilitation (Job 2620)**

Engineering has reviewed the bids opened Tuesday, May 19, 2026 for the WWTP Aeration Tank Covers & Ventilation Stacks Rehabilitation project.

The project involves sandblasting and recoating the fiberglass aeration tank covers and ventilation stacks at the WWTP.

Engineering received four bids. Engineering is recommending accepting the low bid and awarding the contract for \$241,560.00 to Champion Coatings Inc. of Jordan, Minnesota. The Engineer's estimate was \$257,620.00.

Motion made by Councilor Herman to approve. Seconded by Councilor Anderson. On roll call vote, the following councilors voted in favor of said motion: Christensen, Baker, Herman, Olson, Van Beek, Anderson, and Mayor Murray. Mayor Murray declared the motion passed.

(See Secretary's Original Resolution 26-092  
(Included with these minutes)

**C. Resolution 26-093 Authorizing Memorandum of Agreement for the Planning, Construction and Maintenance of Songbird Trail (City of Albert Lea - Freeborn County**

**- Waseca County)**

This resolution authorizes the City Manager to sign a Memorandum of Agreement (MOA) with Freeborn County and Waseca County. The MOA is the agreement on how the Songbird Trail will be planned, constructed and maintained. The MOA is required in order to obtain regional trail designation.

In 2014 the City and County entered into a Joint Powers Agreement regarding the trail. This Memorandum of Agreement replaces the existing agreement.

On May 11, 2026 Freeborn County Engineer, Phil Wacholz presented at the pre-agenda meeting regarding the agreement.

Motion made by Councilor Baker to approve. Seconded by Councilor Herman. On roll call vote, the following councilors voted in favor of said motion: Christensen, Baker, Herman, Olson, Van Beek, Anderson, and Mayor Murray. Mayor Murray declared the motion passed.

(See Secretary's Original Resolution 26-093  
(Included with these minutes)

**D. Resolution 26-094 Denying Final Plat of Dress Second Addition**

City Planner Boeck said the Planning Commission held a public hearing on May 5, 2026 to review the Plat of Dress Second Addition for compliance with Chapter 38 Subdivisions.

The purpose of the plat is to subdivide a smaller 16-acre parcel to provide for a potential residential development. The preliminary plat of Dress Second Addition meets all the requirements of Chapter 38—Subdivisions. However, there are additional utility easements not shown within or along the abandoned Chicago, Milwaukee, St. Paul Railroad. As such, the Planning Commission recommended approval contingent upon the applicant providing evidence or title status including encumbrances and easements.

Since this item was tabled at the previous council meeting, it has been determined that the easement descriptions provided do not describe the property that the existing transmission lines are situated upon and therefore, the final plat does not conform to evidence of title.

In order to meet the MN 60-day rule which requires local government agencies to approve or deny land-use and zoning requests within 60-days, staff recommends denial until easement discrepancies or conflicts can be resolved.

Denying the plat does not mean staff does not support the future development of Dress Second Addition, rather it's due diligence to ensure that there are accurate descriptions of land and property boundaries, compliance with local zoning laws, and clear legal descriptions describing all easements.

Staff recommends denial of the final plat of Dress Second Addition based on the above findings.

City Planner Boeck and City Attorney Holstad responded to council's questions.

Motion made by Councilor Christensen to approve. Seconded by Councilor Baker. On roll call vote, the following councilors voted in favor of said motion: Christensen, Baker, Van Beek, Anderson, and Mayor Murray. Councilors Herman and Olson voted Nay. Mayor Murray declared the motion passed.

(See Secretary's Original Resolution 26-094  
(Included with these minutes)

#### **E. Ordinance 26-156 Amending Chapter 8 – Article II. – Animal Control (1<sup>st</sup> Reading)**

This ordinance was first presented at the May 11 council meeting and was tabled to allow time for additional information from the Police Department regarding pet-related complaints, as well as to gather further public input. Since that initial introduction, the term “commercially” has been added to the definition of *Kennels* in Section 8.043, and the redundant kennel definition previously located in Section 8.029 has been removed. All other proposed changes from the first introduction remain unchanged.

Key considerations in this proposal that have stirred public opinion or comments are:

- The removal of animal limits is countered by the additional authority to correct excessive animal ownership if a nuisance or risk is created. Since January 1<sup>st</sup>, 2023, there have been over 3,000 animal complaints and only one citation for violation of the animal limit. That citation is one of several citations to the owner, without which the animal limit citation would never have been issued.
- Animals running at large. Originally focused on dogs, the ordinance now adds cats. As before, an owner is not allowed to let their animal run at large. This does not necessarily mean a leash when the animal is outside. It means once off the owner's property, a cat or dog has to be under their physical control. A leash is an example in the definition of control and not running “at large”.
- Prohibition of feeding stations does not mean people cannot help with the stray or feral population. It means these efforts are to be done in coordination or part of some larger animal management effort, which includes trap, fix, and rehome/release to eventually reduce the overpopulation, not counter such programs with colonies that are breeding grounds. The Humane Society has vaccinated and fixed 944 cats since 2024, and Camp Companion has trapped and fixed 409 cats.

Councilor Christensen opposes limiting the number of dogs and cats. She noted several reasons.

Motion made by Councilor Herman to amend the proposed ordinance to keep the limit to two dogs and two cats, and approve all the other amendments included in this proposed ordinance. Councilor Olson seconded. Councilor Herman motioned to rescind his first motion. His new motion is to allow any combination of dogs or cats not to exceed a total of four, Councilor Olson does not

support that amendment. Councilor Anderson seconded Herman's motion. On roll call vote, the following councilors voted in favor of said motion: Baker, Herman, Anderson, and Mayor Murray. And the following voted nay: Councilors Christensen, Olson, and Van Beek. Mayor Murray declared the motion passed.

(See Secretary's Original Ordinance 26-156  
(Included with these minutes)

**F. Resolution 26-095 Authorizing Application, Acceptance, and Entering into a Grant Agreement with The State of Minnesota Department of Public Safety for the FY 2027 DWI/Traffic Safety Officer.**

This position is 119% of the salary of a patrol officer. This position is focused on traffic safety. Within the department, if the position is not funded with grants in the future, the position would be removed through attrition. Given the size of the department and the rates of retirement or resignation, this would not create a long-term fiscal constraint.

Motion made by Councilor Baker to approve. Seconded by Councilor Herman. On roll call vote, the following councilors voted in favor of said motion: Christensen, Baker, Herman, Olson, Van Beek, Anderson, and Mayor Murray. Mayor Murray declared the motion passed.

(See Secretary's Original Resolution 26-095  
(Included with these minutes)

**G. Discussion on Establishing an Economic Development Authority**

City Manager Rigg displayed a PowerPoint. This is a discussion on whether to notice the formation of an Economic Development Authority on June 22, 2026. In the creation of the authority, the city is not obligated at that time to pass a levy amount, commit staff, or finalize structure or joint efforts. It is only creating the authority to act on certain economic development matters not authorized to the Port Authority or the Housing and Redevelopment Authority. All three have clear expectations under statute, even if there are overlaps, and the City can assign such responsibilities and authority to those other agencies. Council agreed to proceed with the public hearing on June 22<sup>nd</sup>, 2026 and provide public notice.

**MAYOR AND COUNCIL REPORTS**

First Ward, Councilor Christensen reported:

- Ward Items – None
- Committee Update – None
- Public Announcements – reminded community members to be a good neighbor.

Second Ward, Councilor Baker reported:

- Ward Items – None
- Committee Update – Will be attending an HRA meeting tomorrow
- Public Announcements – None

Third Ward, Councilor Herman reported:

- Ward Items – Responded to a couple of citizen complaints
- Committee Update – Attended the Park & Rec meeting and received a tour of the new North Lot restrooms, updated on the City Pool painting, and discussed the possibility of adding a porta-potty at Frank Hall Park, and also discussed adding an Eddie Cochran statue at a local park.
- Public Announcements – Participated in the Nation of Patriots celebration

Fourth Ward, Councilor Olson reported:

- Ward Items – None
- Committee Update – Attended an Airport Advisory meeting. Noted the glider competition that took place at the airport last weekend.
- Public Announcements – Mentioned the new baseball team in Albert Lea called the Albert Lea Express, and encouraged everyone to stop out and watch a game. Watched the Nation of Patriots ride by.

Fifth Ward, Councilor Van Beek reported:

- Ward Items – None
- Committee Update – Attended the Library Board meeting, reported growth in the programs.
- Public Announcements – Attended and participated in the Nations of Patriots event. Volunteered as a blackjack dealer at the High School after the graduation party. Mentioned upcoming events.

Sixth Ward, Councilor Anderson reported:

- Ward Items – None
- Committee Update – Will be attending an HRA meeting tomorrow
- Public Announcements – Attended the event at Graceland Cemetery on Memorial Day.

### **MAYOR REPORT:**

Reported the following and provided details of each:

- Met with the Eddie Cochran committee regarding the possibility of an Eddie Cochran statue to be placed downtown or at Frank Hall Park
- Oat Mill documentary organizers
- Was at Kate Radio to discuss raising funds for the Fireworks
- Welcomed the new owners of Martin's Bicycle Shop
- Witnessed the Oath of the new 3<sup>rd</sup> Judicial District Judge
- Attended the Legion Riders event
- Attended Albert Lea High School concert choir
- Attended the EDA meeting
- Attended a meeting regarding new housing
- Attended the Adult Education graduation as well as the High School graduation
- Attended the event at Graceland Cemetery on Memorial Day

- Congratulated the High School Boys track team for making it to State

Mentioned the upcoming events and said they are also listed on the City's website.

### **CITY MANAGER REPORT**

- He will be attending the first Wind Down Wednesday with the Human Rights Commission
- Made several calls to legislators regarding the local sales tax
- Review of the budget
- Toured with a housing developer
- Strategic Plan meeting
- City Clerk's office will be open until 5:00 p.m. on Tuesday, June 2<sup>nd</sup>, to accept affidavit of candidacy
- Will be meeting with the County regarding shared services
- Reminder: school is out for the summer, watch for kids

### **APPROVAL OF CLAIMS**

#### **A. Resolution 26-096 Approving Claims**

- (1) Presentation of Claims Over \$25,000

The attached resolution directs the Mayor and City Treasurer to issue the payment of claims as presented in the Detail of Claims report. In addition, Maras displayed a list of claims over \$25,000 for the public's viewing, transparency, and education.

Motion made by Councilor Anderson to approve as read, seconded by Councilor Baker. On roll call vote, the following councilors voted in favor of said motion: Christensen, Baker, Herman, Olson, Van Beek, Anderson, and Mayor Murray. Mayor Murray declared the motion passed.

(See Secretary's Original Resolution 26-096  
(Included with these minutes)

Councilor motioned Christensen for adjournment; Councilor seconded Van Beek. That there being no further business, the Council meeting adjourns until the next regular meeting of the Albert Lea City Council at 7:00 p.m. on Monday, June 8, 2026. On a voice call vote, all councilors voted in favor of said motion.

Mayor Murray declared the motion passed, and the meeting adjourned.

### **ADJOURNMENT: 8:38 PM**

---

Mayor Rich Murray

---

Daphney Maras  
Secretary of the Council

**WORK SESSION MEETING  
CITY COUNCIL CHAMBERS, CITY OF ALBERT LEA  
May 26, 2026 - 5:30 P.M.**

**PRESENT:** Mayor Rich Murray, Councilors Rachel Christensen, Larry Baker, Ted Herman, Keith Van Beek, Brian Anderson, City Manager Ian Rigg, Public Works Director Steven Jahnke, City Attorney Joel Holstad of Lakes National Law LLP, and City Clerk Daphney Maras.

Councilor Reid Olson arrived at 5:45 PM.

**ADDITIONAL STAFF PRESENT:** Chief of Police Darren Hanson, City Planner Megan Boeck, Human Resource Director Mike Zelenak, Finance Director Kristi Brutlag

**I. REVIEW 2026 DEBT ISSUE – KRISTI BRUTLAG**

**II. REVIEW 2025 GENERAL FUND RESULTS – KRISTI BRUTLAG**

Brutlag delivered a PowerPoint presentation providing updates to the debt and general levy.

**III. REVIEW COUNCIL MEETING AGENDA OF MAY 26, 2026**

City Manager Rigg walked through each agenda item and addressed the council's questions.

**CEREMONIAL ITEMS**

A. Daybreakers Kiwanis Proclamation

**PUBLIC FORUM**

**CONSENT AND APPROVAL OF AGENDA**

- A. Approve Minutes of the May 11, 2026 Regular Council Meeting
- B. Approve Minutes of the May 11, 2026 Work Session
- C. License & Permits
- D. Resolution Approving Purchase of Parks Department Bucket Truck Chassis

City Manager Rigg outlined the addition of a permit authorizing the Moose Lodge to serve alcohol at Hayek Field Park throughout the upcoming adult baseball season.

**PETITIONS, REQUESTS AND COMMUNICATIONS** - None

**UNFINISHED BUSINESS** - None

**NEW BUSINESS**

- A. Resolution Accepting Bid and Awarding Contract for the Front Street Bridge No. 24514 Rehabilitation Project (Job 2605)
- B. Resolution Accepting Bid and Awarding Contract for the WWTP Fiberglass Aeration Tank Covers & Ventilation Stacks Rehabilitation (Job 2620)
- C. Resolution Authorizing Memorandum of Agreement for the Planning, Construction and Maintenance of Songbird Trail (City of Albert Lea - Freeborn County - Waseca County)
- D. Resolution Denying Final Plat of Dress Second Addition

City Planner Boeck summarized the circumstances underlying the recommendation to deny the plat. City Attorney Holstad and Boeck responded to the council's questions.

- E. Ordinance Amending Chapter 8 – Article II. – Animal Control (1<sup>st</sup> Reading)

The Council held an extensive discussion concerning the allowable number of dogs and cats per household.

Councilor Christensen stated that she places confidence in the staff's presentation of the proposed amendments and in the legal opinion provided, noting that enforcing household limits on dogs and cats is not realistically feasible. Councilor Van Beek concurred but said his mind could change.

Councilor Anderson stated that the debate over the number of dogs and cats appears to be driven more by emotion than by logic.

Councilor Herman proposed retaining a numerical limit while adopting the remaining amendments to the ordinance. He stated that enforcement decisions ultimately rest with the responding officer.

Councilor Olson supports keeping the limit at two dogs and two cats.

- F. Resolution Authorizing Application, Acceptance, and Entering into a Grant Agreement with The State of Minnesota Department of Public Safety for the FY 2027 DWI/Traffic Safety Officer
- G. Discussion on Establishing an Economic Development Authority

**MAYOR AND COUNCIL REPORTS**

**CITY MANAGER REPORT**

**APPROVAL OF CLAIMS**

- A. Resolution Approving Claims

(1) Presentation of Claims Over \$25,000

**ADJOURNMENT** – 6:52 p.m.

Dated May 26, 2026

---

Daphney Maras  
Council Secretary

## **5C - Licenses and Permits**

*Council Approval 06-08-2026*

---

**All Licenses Listed Are Located In Albert Lea Unless Otherwise Indicated**

### **MOBILE VENDOR**

*Kee Kafe, LLC DBA Bummys BBQ - Kiester, MN*

*Ruthies Ice Cream Sandwiches*

*Nels Diner #1*

*Nels Diner #2*

*B-Lo Zero Sno Cones*

*Gourmet Minne Donuts*

*Golden Hour Dirty Soda*

### **TREE TRIMMER**

*Larson Services LLC*

*From the Ground Up - Owatonna, MN*

*Attig Tree Service - Glenville, MN 56036*

*O'Connell Tree Service LLC - Hollandale, MN*

*Johnson Construction & tree Service LLC - Austin, MN*

*Pat's Tree Service LLC - Lyle, MN*

*Coles Complete Tree Care - Austin, MN*

### **GARBAGE HAULER**

*Thompson Sanitation Inc. - Clarks Grove, MN*

### **ON-SALE LIQUOR LICENSE**

*LV Petroleum, LLC - Las Vegas, NV (purchased former Trails Travel Center)*

### **ON-SALE LIQUOR LICENSE - 3.2%**

*Jake's Pizza*

### **OFF-SALE LIQUOR LICENSE - 3.2%**

*Hy-Vee Grocery*

*Harold's Bar*

### **SIGN HANGER**

*Indigo Signworks, Inc. DBA Indigo Signs - Alexandria, MN*

*Winkels Electric, Inc. - Rochester, MN*

*Precision Signs Service & Install, LLC - Austin, MN*

**MASSAGE THERAPIST**

*Rest & Restore Massage Studio - Brooke Leedom*

*Eleventh Ray Healing LLC - Rachel R. Thompson*

*Emily Grace Toresdahl - Allure Salon and Spa*

RESOLUTION 26

Introduced by Councilor

RESOLUTION APPROVING PLANS AND SPECIFICATIONS AND ORDERING  
ADVERTISEMENT OF BIDS FOR THE AIRPORT SNOW REMOVAL EQUIPMENT DOOR  
REPLACEMENT PROJECT (JOB 2608)

WHEREAS, pursuant to a resolution passed by the council on January 26, 2026, the City Engineer has prepared plans and specifications for the Airport Snow Removal Equipment Door Replacement Project, Job 2608. The work involves replacing two smaller doors with one large 45 foot door; and

WHEREAS, the City will receive a 70 percent state grant and 30 percent local funding grant for the project.

NOW, THEREFORE, BE IT RESOLVED BY THE CITY COUNCIL OF ALBERT LEA, MINNESOTA:

Sec. 1. A copy of the plans and specifications are available for review.

Sec. 2. The City Clerk shall prepare and cause to be inserted in the official newspaper and in the QuestCDN an advertisement for bids upon the making of such improvement under such approved plans and specifications. The advertisement shall be published in each of said publications at least once not less than three weeks and shall specify the work to be done. Any bidder whose responsibility is questioned during consideration of the bid will be given an opportunity to address the council on the issue of responsibility. No bids will be considered unless sealed and filed with the Clerk and accompanied by a cash deposit, cashier's check, bid bond or certified check payable to the clerk for 5% percent of the amount of such bid.

That the motion for the adoption of the foregoing resolution was duly seconded by Councilor , and upon a vote being taken thereon, the following voted in favor thereof: Councilors Christensen, Baker, Herman, Olson, Van Beek, Anderson and Mayor Murray;

And the following voted against the same: None. Mayor Murray declared the resolution passed.

Introduced and passed this 8<sup>th</sup> day of June, 2026

---

Mayor Rich Murray

Filed and attested this 9<sup>th</sup> day of June, 2026

---

Secretary of the Council

ORDINANCE 26-156

Introduced by Councilor

**AN ORDINANCE AMENDING CHAPTER 8 – ANIMALS  
ARTICLE II. – ANIMAL CONTROL**

THE CITY COUNCIL OF ALBERT LEA, MINNESOTA, ORDAINS:

Chapter 8 – Animals, Article II. – Animal Control be amended to read as follows:

**Sec. 8.029. Definitions.**

For the purposes of this ordinance, a service animal is defined in accordance with the Americans with Disabilities Act (ADA) as a dog that is individually trained to do work or perform tasks for a person with a disability. Emotional support animals, comfort animals, or therapy animals that do not meet this definition are not considered service animals and are subject to all regulations applicable to pets.

The following words, terms, and phrases, when used in this article, shall have the meanings ascribed to them in this section, except where the context clearly indicates a different meaning:

*Altered* means any female dog or cat that has been spayed or any male dog or cat that has been neutered.

*Animal* means a dog, a cat, or both.

*At large* means off the premises of the owner and not under the physical control (by leash) of the owner, a member of the owner's immediate family, or a person designated by the owner.

*Feral or Stray Cat*: Any domesticated cat that is unowned, unsocialized to humans, and typically lives outdoors without direct human supervision or care.

*Owner* means any person who owns, harbors, keeps, or has custody of a dog or cat, or the parents or guardians of a person under eighteen (18) years of age who owns, harbors, keeps, or has custody of an animal.

*Multifamily residence* means a building or structure that is designed to house several different families in separate housing units, including, but not limited to, apartment complexes, attached townhomes, and duplexes.

*Restrained* means within the limits of the owner's property or while confined within a vehicle being driven or parked on the streets or under the physical control of a leash by the owner or a person of suitable age and discretion. Any animal not restrained is deemed at large.

*Service animal* means a dog or a miniature horse.

*A household* means a standalone structure with its own lot and intended for one (1) family.

*Unreasonably and/or excessively disturbs the peace* means, but is not limited to, the creation of any noise by any animal which can be heard by any persons, from a location off the owner's

property where the animal is being kept and which noise occurs repeatedly over at least a five (5) minute period of time with one (1) minute or less lapse of time between each noise during the five (5) minute period.

**Sec. 8.030. Exemptions.**

- (a) Hospitals and clinics operated by licensed veterinarians exclusively for the care and treatment of animals are exempt from this article except where such duties are expressly stated.
- (b) Service animals, properly trained as such and under the control of an owner, are exempt from this article.

**Sec. 8.031. Animal control authority.**

The city manager is authorized to employ animal control authorities for the enforcement of this article and to have them deputized with police powers for such enforcement, including authority to issue complaints for the violation of this article.

- (1) Any person who owns, possesses, or harbors an animal within the city limits grants implied consent for entry upon his premises, without express consent, to the animal control authority or police officers for the purpose of enforcing the provisions of this article.
- (2) No unauthorized person shall break open the animal shelter or attempt to do so, or to take or let out any dogs or cats therefrom, or to take from any animal control authority any dog or cat taken up by them in compliance with city ordinance, or in any manner to interfere, hinder, or obstruct an animal control officer in the discharge of their duties under any ordinance of the city.

**Sec. 8.032. Impoundment.**

- (a) Any animal found in the city without a license tag, running at large or otherwise in need of impoundment under this article shall be placed in the animal shelter, and an accurate record of the time of such placement shall be kept on each animal.
- (b) Except as otherwise provided in this article, an owner or his representative may reclaim any animal from the shelter upon proof of and/or payment of the required license fee, impound fee, and the daily maintenance costs imposed by the animal shelter.
- (c) Any animal that has bitten a person shall immediately be impounded for at least fourteen (14) days and kept apart from other animals. The animal must be impounded at the shelter or with a licensed veterinarian at the owner's expense, except that an animal with proof of current rabies vaccination may be impounded by its owner.
- (d) Any animal adopted through the animal shelter over the age of six (6) months shall be altered within thirty (30) days of adoption. The animal control authority is responsible for enforcing this subsection.

**Sec. 8.033. Limitation on Ownership.**

(a) **Household.** It shall be a petty misdemeanor for any person to own, keep, care for, have custody of, or knowingly permit at any time more than four (4) total dogs and/or cats in or about any household. A household may contain any combination of dogs and cats, provided the total number does not exceed four (4); however, this section shall not apply to the following:

1. One litter of pups or kittens under ninety (90) days of age born to a licensed dog or cat owner; or
2. Residents of newly annexed areas with more than any combination of four (4) dogs and/or cats at the time of annexation may have the additional animals until such time as one (1) of the animals existing at the time of annexation is no longer owned or possessed by the owner.

(b) **Community Responsibility Standard.**

Owners must ensure that:

1. Animals are not kept in unsanitary or overcrowded conditions.
2. Noise, odor, and waste from animals are properly controlled.
3. Animals do not disturb neighbors, roam at large, or threaten the safety of people, other animals, or property.
4. The number of animals kept is manageable to the extent that each animal receives adequate care, shelter, food, water, medical attention, and humane treatment.
5. Maintain medical records showing rabies and other vaccinations to prevent the spread of infections and diseases among humans and animals.

(c) **Feral Cats.**

It is prohibited to intentionally feed or otherwise provide sustenance to feral or stray cats on public or private property unless part of a city-approved trap-neuter-return (TNR) program. Feeding feral cats without authorization contributes to overpopulation and health risks, and individuals found doing so may be subject to citation. The city encourages humane and coordinated efforts to manage feral cat populations in partnership with local animal welfare organizations.

(d) **Inspection and Enforcement.**

The city reserves the right to inspect properties upon receiving a complaint or having reason to believe that animals are being kept in violation of this ordinance. The city may order the reduction in the number of animals kept on a property if it is determined that the keeping of animals constitutes a nuisance, threat to public health, or is inconsistent with community standards of care and safety.

**Sec. 8.034. License.**

- (a) No person shall own, keep, or harbor any dog or cat of more than six (6) months of age without obtaining a license from the city. A license application must recite the name and address of the owner, the address where the animal will be kept, and the sex, breed, age, color, and markings of the dog or cat, and include a certificate of rabies vaccination for which a license is sought.
- (b) No license shall be issued without a certificate of vaccination against rabies from a licensed veterinarian. An owner must keep the dog or cat vaccinated against rabies at all times.
- (c) Upon payment of the license fee established by the annual fee schedule, the city shall keep a record of all licenses and issue a license tag for such license. The license tag must be fastened to the collar so it can be worn by the animal at all times. Lost license tags may be replaced upon presentation of the owner's payment receipt for the current year.
- (d) Licenses must be renewed by April 1 every three years within 60 days of the most recent vaccination. The fees for licenses are set in the city's annual fee schedule.
- (e) Licenses must be obtained within ninety (90) days of establishing residence or annexation in the city.
- (f) When an application is made for an altered dog or cat, proof that the animal has been altered by a licensed veterinarian must be presented at the time of application for a license.
- (g) Dog and cat licenses are non-transferable. No refunds will be given due to the death of the animal or a change of residence.
- (h) The licensing requirements of this section shall not apply to any animal belonging to a nonresident of the city, provided that the animal is not kept within the city limits for longer than thirty (30) days. The animal must be restrained at all times.
- (i) Violation of this section is a misdemeanor.

**Sec. 8.035. Dogs and Cats running at large.**

It is a petty misdemeanor for any owner to permit a dog or cat to run at large at any time beyond the limits of the land owned by or possessed by the owner, keeper, or harbored, or upon the public streets or sidewalks, or other public or private property within the city. If a violation of this section occurs, it shall be no defense that the offending dog escaped or is otherwise at large without the permission of its owner.

**Sec. 8.036. Prohibited in public places.**

No animal shall be allowed in city parks and picnic areas unless restrained and attended by the owner or a person of suitable age and discretion. No animal shall be permitted in the municipal bathhouse or within the confines of the municipal outdoor swimming pool, except as allowed during city-sponsored events.

**Sec. 8.037. Nuisances prohibited.**

- (a) The following are public nuisances and unlawful:
  - (1) Any animal which habitually barks, cries, or howls and unreasonably and/or excessively disturbs the peace of any person in the vicinity.
  - (2) Any animal that kills or attacks another domestic animal or livestock without provocation while off the owner's property.
  - (3) Any animal that damages property (that is not the property of the owner), including plantings, lawns, structures, or that deposits fecal matter on the owner's property that the owner fails to remove promptly.
  - (4) Any animal that, without provocation, chases, molests, or approaches pedestrians or bicyclists in a threatening manner upon the streets, sidewalks, right-of-way, or any public property, or habitually chases automobiles on the public streets or highways.
  - (5) Any animal that is kept under unsanitary and/or inhumane conditions, such that the maintenance or keeping of the animal creates odors to the annoyance of the public in the vicinity.
- (b) Any person who owns or harbors an animal declared to be a nuisance shall be guilty of a misdemeanor.

**Sec. 8.038. Sanitation.**

- (a) Any person who owns, keeps, or harbors any animal is responsible to keep his property clean of all fecal matter from the animal. All animal waste should be removed daily so as to keep the surrounding area free from obnoxious odors.
- (b) No animal may defecate upon public property or private property without the consent of the property owner, unless the owner or person in charge of the animal immediately removes animal waste from the affected area and provides proper disposal.
- (c) Proper disposal of animal waste shall be limited to bagging for disposal by the owner or person in charge of the animal's own waste receptacle, and bagging for disposal in a waste receptacle in a public park or park area.
- (d) The provisions stated in section 8.038 do not apply to seeing-eye dogs under the control of a blind person.
- (e) Violation of this section is a petty misdemeanor.

**Sec. 8.039. Care.**

No owner shall fail to provide any animal with sufficient good and wholesome food and water, proper shelter and protection from the weather, veterinarian care when needed to prevent suffering, and humane care and treatment. No person shall beat, cruelly ill-treat, torment, or

otherwise abuse any animal or cause or permit any animal fight or other combat between animals and humans.

**Sec. 8.040. Rabies.**

- (a) All dogs over the age of six (6) months shall be inoculated for rabies, and shall be re-inoculated within the time required by the vaccination. A certificate of the veterinarian inoculating said dog or cat shall be provided with the license application.
- (b) The animal control authority shall issue a proclamation ordering every person owning or keeping an animal securely confined on its property whenever the prevalence of rabies renders such action necessary to protect the public health and safety. Violation of such proclamation is unlawful, and any animal running at large during this period may be destroyed by the enforcement authority without notice to the owner.

**Sec. 8.041. Potentially dangerous dogs and dangerous dogs.**

- (a) The owner of a dog deemed potentially dangerous may be provided a summary review before requesting an appeal
- (b) *Attack by a dog.* It shall be unlawful for any person's dog to inflict or attempt to inflict bodily injury to any person or domestic animal, whether or not the owner is present. This subsection shall not apply to an attack by a dog under the control of an on-duty law enforcement officer or to an attack upon an uninvited intruder who has entered the owner's property with criminal intent.
- (c) *Destruction of a dangerous dog.* The animal control authority shall have the right to order the destruction of dangerous dogs in accordance with the terms established by this article.
- (d) *Definitions.* The following words, terms, and phrases, when used in this section, shall have the meanings ascribed to them in this subsection, except where the context clearly indicates a different meaning:

*Dangerous dog* means a dog that has:

- (1) Without provocation, inflicted substantial bodily harm to any person on public or private property.
- (2) Killed a domestic animal without provocation while off the owner's property.
- (3) A known propensity, tendency, or disposition to attack unprovoked, causing injury or threatening the safety of humans or domestic animals.
- (4) Been found that the owner has personal knowledge of the same, and has aggressively bitten, attacked, or endangered the safety of people or domestic animals.

*Domestic animal* means an animal kept for companionship and enjoyment as opposed to livestock, including, but not limited to, dogs, cats, caged birds, gerbils, hamsters, domesticated rabbits, guinea pigs, nonpoisonous, nonvenomous, and non-constricting reptiles and amphibians, and other similar animals.

*Potentially dangerous dog* means a dog that has:

- (1) Without provocation, chased or approached a pedestrian or bicyclist on or upon the streets, sidewalks, or any public or private property, other than the dog owner's property, in an apparent attitude of attack.
- (2) A known propensity, tendency, or disposition threatening the safety of people or domestic animals.

*Proper enclosure* means securely confined indoors or in a securely locked pen or structure suitable to prevent the dog from escaping and to provide protection for the dog from the elements. The term "proper enclosure" does not include a porch, patio, or any part of a house, garage, or other structure that would allow the dog to exit of its own volition, or any house or structure in which windows are open or in which door or window screens are the only barriers that prevent the dog from exiting. The enclosure shall not allow the egress of the dog in any manner without assistance from a person.

*Substantial bodily harm* means bodily injury which involves a temporary but substantial disfigurement, or which causes a temporary but substantial loss or impairment of the function of any bodily member or organ, or which causes a fracture of any bodily member, as it may be amended from time to time.

*Unprovoked* means the condition in which the dog is not purposely excited, stimulated, agitated, or disturbed.

- (d) When a dog is declared a potentially dangerous dog, the animal control authority shall cause one (1) owner of the potentially dangerous dog to be notified in writing that the dog is potentially dangerous.
- (e) When a dog is declared a dangerous dog, the animal control authority shall cause one (1) owner of the dangerous dog to be so notified, and notify that owner of his appeal rights.
- (f) *Authority to order destruction.* The animal control authority, upon finding that a dog is dangerous hereunder, is authorized to order, as part of the disposition of the case, that the dog be destroyed, based on a written order containing one (1) or more of the following findings of fact:
  - (1) The dog is dangerous, as demonstrated by a vicious attack, an unprovoked attack, an attack without warning, or multiple attacks.
  - (2) The owner of the dog has demonstrated an inability or unwillingness to control the dog to prevent injury to persons or domestic animals.
- (g) *Appeal hearing procedures—Dangerous dog.*
  - (1) The owner of a dog that has been declared dangerous may appeal the declaration and request a hearing. The appeal request is to be submitted in writing within fourteen (14) days of notification. If a hearing is requested, the animal control authority or the designee shall schedule a hearing within fourteen (14) calendar days. A dangerous declaration appeal shall consist of an appearance before an independent city employee or hired representative. The fee for an appeal of a dangerous dog declaration is noted in the city's annual fee schedule and must be paid before the hearing. The hearing authority may set limits on the evidence that may be submitted and the length of

testimony offered. The hearing officer conducting the review shall have the authority to amend the declaration or order as appropriate and to establish specific requirements. Any time after a declaration has been issued, the animal control authority or the designee may seize a declared dog. All applicable fees and costs shall be the responsibility of the owner of the dog. The dog should not be released until all fees are paid in full and the owner has fully complied with the provisions of this Code. All dogs seized pursuant to this subsection may be disposed of by animal control after fourteen (14) calendar days of notification of declaration when the dog is not properly registered or an appeal has not been properly submitted pursuant to this section.

- (2) In the event the declaration is overturned, all fees will be reviewed by the hearing officer. The owner of the dog shall be notified by telephone of the hearing results within ten (10) business days. All decisions may be appealed to the state court of appeals.
- (3) The animal control authority, after having determined that a dog is dangerous, may proceed in the following manner:
  - a. The animal control authority shall cause one (1) owner of the dog to be notified in writing or in person that the dog is dangerous and may order the dog seized or make orders as deemed proper. This owner shall be notified as to dates, times, places, and parties bitten, and shall be given fourteen (14) days to appeal this order by requesting a hearing for a review of this determination.
  - b. If no appeal is filed, the animal control authority may authorize the seizure and the destruction of the dog, unless the dog is already in custody or the owner consents to the seizure and destruction of the dog.
  - c. If an owner requests a hearing for determination as to the dangerous nature of the dog, the hearing shall be held before an impartial employee of the local government or impartial person retained by the local government, which shall set a date for the hearing not more than three (3) weeks after demand for the hearing. The records of the animal control or city clerk's office shall be admissible for consideration by the hearing officer without further foundation. After considering all evidence pertaining to the temperament of the dog, the hearing officer shall make an order as it deems proper. The hearing officer shall issue a decision on the matter within ten (10) days after the hearing. The decision must be delivered to the dog's owner by hand delivery or registered mail as soon as practical, and a copy must be provided to the animal control authority. The animal control authority may take the dog into custody for destruction if the dog is not currently in custody. If the dog is ordered into custody for destruction, the owner shall immediately make the dog available to the animal control authority. If the owner does not immediately make the dog available, the animal control authority shall obtain an order or warrant authorizing the seizure and the destruction of the dog from a court of competent jurisdiction. In the event the dangerous dog declaration is upheld by the hearing officer, actual expenses for the hearing may be the responsibility of the dog's owner.

- d. No person shall harbor a dog after it has been found to be dangerous and ordered into custody for destruction.
- (4) The city hereby adopts the procedures outlined in Minn. Stats. § 347.541 for the disposition of seized dogs and hearings and incorporates the same by reference, as may be amended from time to time.
- (h) *Stopping an attack.* If any police officer or animal control authority is witness to an attack by a dog upon a person or domestic animal, the officer may take whatever means deemed appropriate to end the attack and prevent further injury.
- (i) *Notification of new address.* The owner of a dog that has been identified as dangerous or potentially dangerous shall notify the animal control authority in writing if the dog is to be relocated from its current address or given or sold to another person. The notification shall be given in writing at least fourteen (14) days before the relocation or transfer of ownership. The notification shall include the current owner's name and address, the relocation address, and the name of the new owner, if any.
- (j) *Dangerous dog requirements.* If the animal control authority or hearing officer does not order the destruction of a dog that has been declared dangerous, he may, as an alternative, order any or all of the following:
  - (1) That the owner provides and maintains a proper enclosure for the dangerous dog as defined in subsection (c) of this section.
  - (2) Post at the front and the rear of the premises with clearly visible warning signs that there is a dangerous dog on the property, including a warning symbol to inform children, as specified in Minn. Stats. § 347.51;
  - (3) Provide and show proof annually of public liability insurance in the minimum amount of three hundred thousand dollars (\$300,000.00).
  - (4) If the dog is outside the proper enclosure, the dog must be muzzled and restrained by a substantial chain or leash (not to exceed six (6) feet in length) and under the physical restraint of a person sixteen (16) years of age or older. The muzzle must be of a design to prevent the dog from biting any person or domestic animal, but will not cause injury to the dog or interfere with its vision or respiration.
  - (5) The dog shall have a microchip implant as provided by Minn. Stats. § 347.515.
  - (6) All dogs deemed dangerous by the animal control authority shall be registered with the city within fourteen (14) days after the date the dog was so deemed and provide satisfactory proof thereof to the animal control authority. Continuing registration is required.
  - (7) The dog must be licensed annually as a dangerous dog by April 1 in addition to a standard pet license, and pay the fee established by the annual fee schedule.
- (k) *Seizure.* As authorized by Minn. Stats. § 347.54, the animal control authority shall immediately seize any dangerous dog if the owner does not meet each of the requirements under subsection (j) of this section within fourteen 14 days after the date notice is sent to the

owner that the dog is dangerous. A seizure may be appealed to the district court by serving a summons and petition upon the city and filing it with the district court.

- (l) *Reclaiming dogs.* A dangerous dog seized may be reclaimed by the owner upon payment of impounding and boarding fees and presenting proof to animal control that each of the requirements under subsection (j) of this section is fulfilled. A dog not reclaimed under this subsection within fourteen (14) days may be euthanized, and the owner is liable to the city for costs incurred in confining and impounding the dog.
- (m) *Subsequent offenses.* If an owner of a dog has subsequently violated the provisions under subsection (j) of this section with the same dog, the dog must be seized by animal control. The owner may request a hearing as defined in subsection (g) of this section. If the owner is found to have violated the provisions for which the dog was seized, the animal control authority shall order the dog destroyed properly and humanely, and the owner shall pay the costs of confining the dog. If the person is found not to have violated the provisions for which the dog was seized, the owner may reclaim the dog under the provisions of subsection (l) of this section. If the dog is not yet reclaimed by the owner within fourteen (14) days after the date the owner is notified that the dog may be reclaimed, the dog may be disposed of as provided under subsection j) of this section, and the owner is liable to animal control for the costs incurred in confining, impounding, and disposing of the dog.

**Sec. 8.042. Other Seizure and Disposal.**

- (a) Violations of Section 8.033(b) may cause seizure of animals.
- (b) When an animal may be rehabilitated to proper health or meet the provisions under Section 8.041(j), the animal control authority may rehome the animal.

**Sec. 8.043. Kennels Prohibited.**

No person shall operate, maintain, or permit a kennel within the City limits. For purposes of this section, a "kennel" means any premises where four or more dogs, four or more cats, or any combination of six or more dogs and cats over the age of six months are commercially kept, boarded, bred, trained, or offered for sale. Refer to Chapter 50 within the municipal code for all zoning requirements related to commercial kennels or runs.

**Secs. 8.044 - 8.070. – Reserved**

That the motion for the adoption of the foregoing ordinance was duly seconded by Councilor Anderson, and upon a vote being taken thereon, the following voted in favor thereof: Councilors Baker, Herman, Anderson, and Mayor Murray.

And the following voted against the same: Councilors Christensen, Olson, and Van Beek. Mayor Murray declared the ordinance passed.

Introduced the first time on the 26<sup>th</sup> day of May, 2026

---

Mayor Rich Murray

Filed and attested this 26<sup>th</sup> day of May, 2026

---

Secretary of the Council

RESOLUTION 26-

Introduced by Councilor

RESOLUTION PERMITTING PUBLICATION OF ORDINANCE SUMMARY AMENDING  
CHAPTER 8 - ANIMALS ARTICLE II. - ANIMAL CONTROL

WHEREAS, on June 8, 2026, the Albert Lea City Council held a regular city council meeting and approved amendments to Chapter 8 - Animals Article II. - Animal Control.

WHEREAS, the entirety of this ordinance is lengthy, and a summary of the ordinance shall be drafted, which will reasonably inform the public of the intent and effect of the amended ordinance.

NOW THEREFORE, BE IT RESOLVED BY THE CITY COUNCIL OF ALBERT LEA, MINNESOTA:

Sec. 1. That the City Clerk is directed to publish a summary of the Ordinance as drafted.

Sec. 2. The summary will reasonably inform the public of the intent and effect of Ordinance 26-156.

That the motion for the adoption of the foregoing resolution was duly seconded by Councilor, and upon a vote being taken thereon, the following voted in favor thereof: Councilors Christensen, Baker, Herman, Olson, Van Beek, Anderson, and Mayor Murray.

And, the following voted against the same: None.

Introduced and passed on the 8<sup>th</sup> day of June, 2026

---

Mayor Rich Murray

Filed and attested the 9<sup>th</sup> day of June, 2026

---

Secretary of the Council

ORDINANCE 26-156 (SUMMARY)

**THE CITY COUNCIL OF ALBERT LEA, MINNESOTA ORDAINS:**

On June 8, 2026, the Albert Lea City Council held a regular city council meeting and amended Chapter 8 – Article II. – Animal Control

The proposed amendments to the Animal Control ordinance update and modernize the city's approach to responsible pet ownership, public safety, and community expectations. Several sections of the existing ordinance were outdated or no longer aligned with current best practices, enforcement needs, or community concerns. The revisions aim to clarify definitions, strengthen nuisance and safety provisions, and ensure consistent, enforceable standards for both pet owners and animal control staff.

**Sec. 8.029. Definitions.**

The ordinance updates and expands key definitions to remove ambiguity and improve enforcement.

**Sec. 8.033 – Limitation on Ownership.**

The ordinance removes the previous limit of two dogs and two cats allowed in a household and now states it shall be a petty misdemeanor for any person to own, keep, care for, have custody of, or knowingly permit, at any time, more than four (4) total dogs and/or cats in or about any household. A household may contain any combination of dogs and cats, provided the total number does not exceed four (4); however, this section shall not apply to the following:

1. One litter of pups or kittens under ninety (90) days of age born to a licensed dog or cat owner; or
2. Residents of newly annexed areas with more than any combination of four (4) dogs and/or cats at the time of annexation may have the additional animals until such time as one (1) of the animals existing at the time of annexation is no longer owned or possessed by the owner.

**Sec. 8.033 (c) Feral Cat Management and TNR Programs.**

This is a new section that addresses community concerns about feral cat overpopulation. Feeding feral cats would be prohibited unless part of a city-approved trap-neuter-return (TNR) program. This approach would: (list above)

**Sec. 8.033** also adds law enforcement tools, including those to address recurring neighborhood concerns, and provides clearer enforcement pathways.

The city reserves the right to inspect properties upon receiving a complaint or having reason to believe that animals are being kept in violation of this ordinance. The city may order the reduction in the number of animals kept on a property if it is determined that the keeping of animals

constitutes a nuisance, threat to public health, or is inconsistent with community standards of care and safety.

**Sec. 8.034.**

Licensing and Vaccination updates: The ordinance clarifies licensing timelines, rabies vaccination requirements, and renewal procedures. It also reinforces that licensing violations are misdemeanors.

**Sec. 8.043. Kennels prohibited.**

This is a new addition to the ordinance and defines a kennel and the prohibition within city limits. It states that no person shall operate, maintain, or permit a kennel within the City limits. For purposes of this section, a “kennel” means any premises where four or more dogs, four or more cats, or any combination of six or more dogs and cats over the age of six months are commercially kept, boarded, bred, trained, or offered for sale. Refer to Chapter 50 within the municipal code for all zoning requirements related to commercial kennels or runs.

The ordinance was adopted by the City Council of the City of Albert Lea on the 8<sup>th</sup> day of June, 2026.

A complete copy of this Ordinance is available for inspection and copying during regular business hours at the Albert Lea City Hall located at 221 East Clark Street, Albert Lea, MN 56007; or for a mailed or emailed copy, call the City Clerk at (507) 377-4335.

/s/ Daphney Maras, City Clerk

RESOLUTION 26-

Introduced by Councilor

RESOLUTION APPROVING PRELIMINARY AND FINAL PLAT OF DRESS SECOND  
ADDITION

WHEREAS, Chapter 38 (Subdivision) of the City Code allows for the platting of land within in the City that will provide harmonious development, coordinated layouts, proper arrangements of streets and utilities, and adequate provisions for water, sewer, drainage and other sanitary facilities; and

WHEREAS, the Planning Commission held a public hearing on June 2, 2026 and reviewed the preliminary plat of Battleson Renchin Addition in accordance with Chapter 38 of the City Code; and

WHEREAS, the Planning Commission and recommends approval of the final plat of Battleson Renchin Addition; and

NOW, THEREFORE, BE IT RESOLVED BY THE CITY COUNCIL OF ALBERT LEA, MINNESOTA:

Sec. 1. That the final plat of Battleson Renchin, prepared by Jones, Haugh & Smith Inc dated April 2026 is approved contingent upon the above stated.

That the motion for the adoption of the foregoing resolution was duly seconded by Councilor , and upon a vote being taken thereon, the following voted in favor thereof: Councilors Christensen, Baker, Herman, Olson, Van Beek, Anderson, and Mayor Murray;

And the following voted against the same: None. Mayor Murray declared the resolution passed.

Introduced and passed this 8<sup>th</sup> day of June, 2026

---

Mayor Rich Murray

Filed and attested this 9<sup>th</sup> day of June, 2026

---

Secretary of the Council

OFFICIAL PLAT

# BATTLESON RENCHIN ADDITION

IN SE1/4 NW1/4 NW1/4 SECTION 21-T102N-R21W  
ALBERT LEA, FREEBORN COUNTY, MINNESOTA

CERTIFICATE OF DEDICATION

KNOW ALL PERSONS BY THESE PRESENTS: That Jon M. Battleson and Krissandra M. Renchin, joint tenants and owners and proprietors of the following described property situated in the City of Albert Lea, County of Freeborn, State of Minnesota, to-wit:

All that part of the Southeast Quarter of the Northwest Quarter of the Northwest Quarter, Section 21 Township 102 North, Range 21 West, Freeborn County, Minnesota; described as follows:  
Commencing at Northeast corner of the Northwest Quarter of Northwest Quarter of said Section 21; thence South 00 degrees 34 minutes 41 seconds East a distance of 666.10 feet, on an assumed bearing on the East line of said Northwest Quarter of the Northwest Quarter, to the point of beginning; thence South 89 degree 41 minutes 40 seconds West a distance of 375.30 feet, on a line parallel with and 666.10 feet South of North line of said Northwest Quarter of the Northwest Quarter; thence North 00 degrees 34 minutes 41 seconds West a distance of 2.68 feet, to a point on the North line of said Southeast Quarter of the Northwest Quarter of the Northwest Quarter thence South 69 degrees 46 minutes 37 seconds West a distance of 284.26 feet, on the North line of said Southeast Quarter of the Northwest Quarter of the Northwest Quarter, to the Northwest corner thereof; thence South 00 degrees 35 minutes 48 seconds East a distance of 661.30 feet, on West line of said Southeast Quarter of Northwest Quarter of the Northwest Quarter, to the Southwest corner thereof; thence North 89 degrees 42 minutes 32 seconds East a distance of 659.49 feet, on the South line of said Southeast Quarter of the Northwest Quarter of the Northwest Quarter, to the Southeast corner thereof; thence North 00 degrees 34 minutes 41 seconds West a distance of 658.37 feet, on East line of said Southeast Quarter of Northwest Quarter of the Northwest Quarter, to the point of beginning.

having caused the above described premises to be surveyed and platted as shown hereon, to be known as BATTLESON RENCHIN ADDITION, and does hereby dedicate to the public for public use the drainage and utility easements as created by this plat.

In witness whereof said Jon M. Battleson and Krissandra M. Renchin, joint tenants have caused these presents to be signed by its proper officer this \_\_\_\_ day of \_\_\_\_\_, 2026.

Jon M. Battleson \_\_\_\_\_ Krissandra M. Renchin \_\_\_\_\_

STATE OF MINNESOTA  
COUNTY OF FREEBORN

This instrument was acknowledged before me this \_\_\_\_ day of \_\_\_\_\_, 2026.

\_\_\_\_\_, Notary Public  
My Commission Expires \_\_\_\_\_

SURVEYOR'S CERTIFICATE

I Steven J. Thompson do hereby certify that this plat was prepared by me or under my direct supervision; that I am a duly Licensed Land Surveyor in the State of Minnesota; that this plat is a correct representation of the boundary survey; that all mathematical data and labels are correctly designed on this plat; that all monuments depicted on this plat have been, or will be correctly set within one year; that all water boundaries and wet lands, as defined in Minnesota Statutes, Section 505.01, Subd. 3, as of the date of this certificate are shown and labeled on this plat; and all public ways are shown and labeled on this plat.

Dated \_\_\_\_ day of \_\_\_\_\_, 2026.

\_\_\_\_\_  
Licensed Land Surveyor  
Minnesota Licensed No. 22705

STATE OF MINNESOTA  
COUNTY OF FREEBORN

This instrument was acknowledged before me on \_\_\_\_ day of \_\_\_\_\_, 2026 by Steven J. Thompson.

\_\_\_\_\_, Notary Public  
My Commission Expires \_\_\_\_\_

CITY APPROVAL

We do hereby certify that the within plat of Battleson Renchin Addition was duly accepted and approved by the City Council of the City of Albert Lea, on the \_\_\_\_ day of \_\_\_\_\_, 2026.

\_\_\_\_\_  
Mayor \_\_\_\_\_ Attest: \_\_\_\_\_  
City Clerk

COUNTY SURVEYOR

I hereby certify that in accordance with Minnesota Statutes, Section 505.021, Subd. 11, this plat has been reviewed and approved this \_\_\_\_ day of \_\_\_\_\_, 2026.

\_\_\_\_\_  
Deputy Freeborn County Surveyor

COUNTY AUDITOR & TREASURER CERTIFICATES

No delinquent taxes due and transfer has been entered this \_\_\_\_ day of \_\_\_\_\_, 2026.

\_\_\_\_\_  
County Auditor, Freeborn County, Minnesota

I hereby certify that on this the \_\_\_\_ day of \_\_\_\_\_, 2026, the current taxes have been paid on the land described herein.

\_\_\_\_\_  
County Treasurer, Freeborn County, Minnesota

COUNTY RECORDER'S CERTIFICATE

County Recorder, County of Freeborn, State of Minnesota

I hereby certify that this plat of Battleson Renchin Addition was filed in the office of the County Recorder for public record on this \_\_\_\_ day of \_\_\_\_\_, 2026, at \_\_\_\_ o'clock \_\_\_\_ M., and was duly filed in Book \_\_\_\_ of Plats, Page \_\_\_\_ as Document Number \_\_\_\_\_.

\_\_\_\_\_  
County Recorder, Freeborn County, Minnesota

By: \_\_\_\_\_  
Deputy

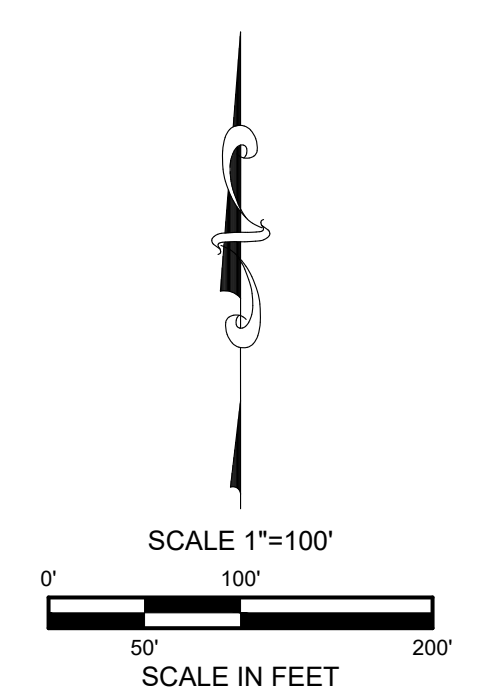
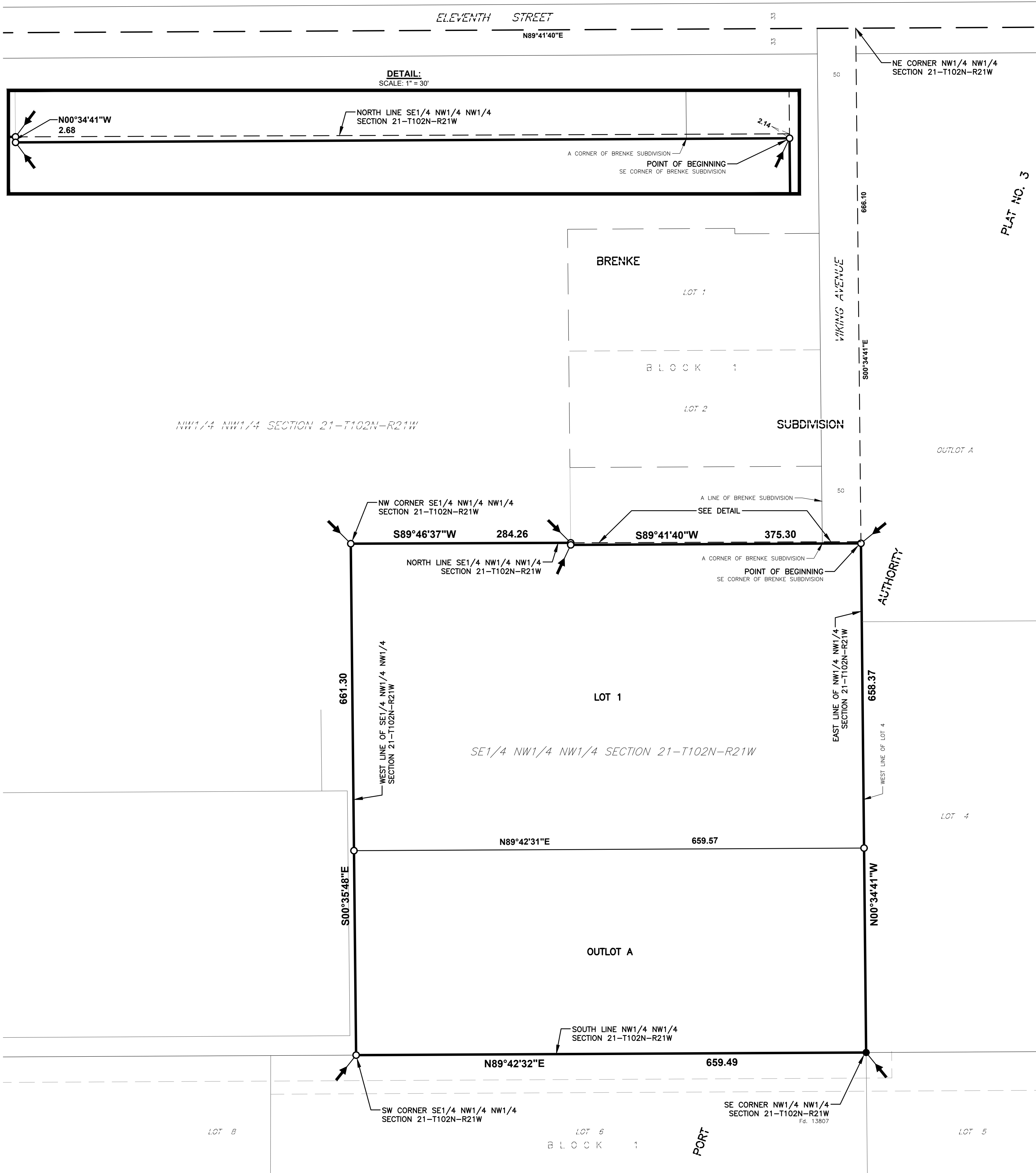

AREA  
9.97 ACRES± (434,211 Ft<sup>2</sup>)

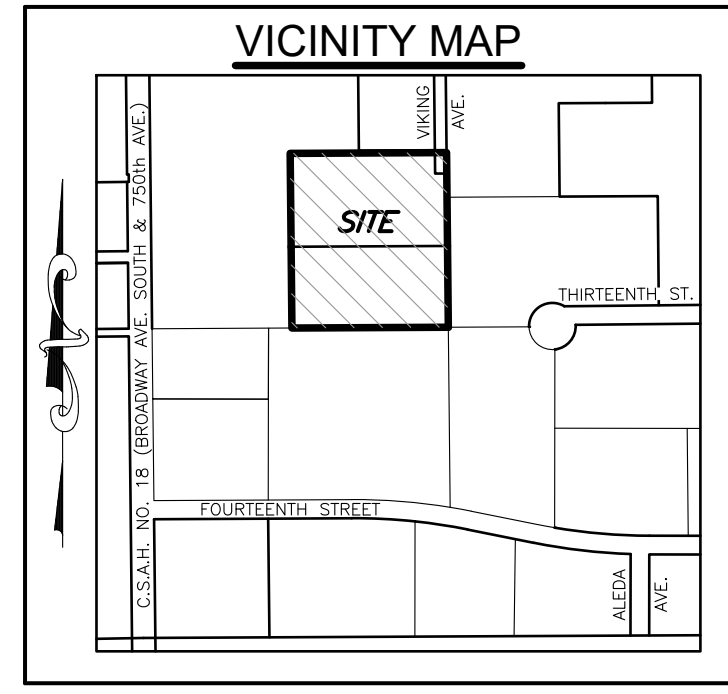

- LEGEND**
- = 5/8 Inch X 16 Inch iron stake monument (capped SJT 22705)-Placed
  - = Iron stake monument - Found
  - ⊙ = Subdivision Plat Corner
  - ⊕ = Utility Easement

**BASIS OF BEARING SYSTEM**

All bearings are based upon the MnDot Freeborn County Coordinate System Nad 83 (96) Harn Adjustment Grid

**COPYRIGHT**

This document is the property of Jones, Haugh & Smith Inc. and may not be used, copied or duplicated without prior written consent.

**JONES, HAUGH & SMITH INC.**  
CONSULTING ENGINEERS & LAND SURVEYORS  
515 SOUTH WASHINGTON AVENUE ALBERT LEA,  
MINNESOTA 56007  
APRIL 2026  
DRAWN BY ANDY MCGOWAN

ORDINANCE 26-

Introduced by Councilor

AN ORDINANCE AMENDING ZONING AND THE LANDUSE MAP FROM SINGLE-FAMILY  
RESIDENCE (R-1) TO INDUSTRIAL DISTRICT (I-2) FOR OUTLOT A OF BATTLESON RENCHIN  
ADDITION

THE CITY COUNCIL OF ALBERT LEA, MINNESOTA ORDAINS:

WHEREAS, Jon Battleson and Krissandra Renchin, the property owners of PID 34.075.0320, have applied to re-zone out A of Battleson Renchin Addition from Single-Family Residence (R-1) to Industrial District (I-2) to accommodate the eventual sale and future expansion with Vortex Cold Storage, and;

WHEREAS, those properties are legally described as Battleson Renchin Addition, Outlot A, Freeborn County, Minnesota, and

WHEREAS, notice of public hearing on the rezoning described above was published in the Official City Newspaper as required by law, and

WHEREAS, the Planning Commission held a public hearing on June 2, 2026 and recommended approval of rezoning the property from Single Family Residence (R-1) to Industrial District (I-2), and

WHEREAS, the Albert Lea City Council finds that the rezoning is reasonable and compatible with the general zoning requirements of the Industrial District (I-2), and

WHEREAS, Albert Lea's zoning map is to be amended by ordinance and approved by the City Council.

NOW, THEREFORE, BE IT ORDAINED BY THE CITY COUNCIL OF ALBERT LEA, MINNESOTA:

Sec. 1. That the above-described properties be rezoned from Single Family Residence (R-1) to Industrial District (I-2).

That the motion for adoption of the foregoing ordinance was duly seconded by Councilor , and upon a vote being taken thereon, the following voted in favor thereof: Councilors Christensen, Baker, Herman, Olson, Van Beek, Anderson, and Mayor Murray;

And, the following voted against the same: None.

Introduced and read the first time on this 8<sup>th</sup> day of June 2026

---

Mayor Rich Murray

Filed and attested this 9<sup>th</sup> day of June 2026

---

Secretary of the Council

RESOLUTION 26-

Introduced by Councilor

RESOLUTION APPROVING CONDITIONAL USE PERMIT FOR BRIDGE #R1144  
REPLACEMENT

WHEREAS, the City of Albert Lea applied for a conditional use permit for pedestrian bridge replacement in the F-1 Floodway District; and

WHEREAS, the bridge is part of the Songbird Trail development and is situated in the former Union Pacific Railroad corridor; and

WHEREAS, the existing pedestrian bridge is being replaced to correct safety issues; and

WHEREAS, the recently adopted 2040 Comprehensive Plan designates Songbird Trail as a future trail connection; and

WHEREAS, the Advisory Planning Commission held a public hearing on Tuesday, May 5, 2025 and made the following findings:

1. The application is consistent with the 2040 Comprehensive Plan.
2. The proposed bridge meets the conditions of F-1 Floodway District by not impacting public waters or wetlands, having proper erosion and sediment prevention plans and by implementing a design that will not change current flow characteristic of the channel from what is existing.
3. The proposed bridge is compatible with the surrounding uses and will not negatively impact the public health safety and welfare of the surrounding area.

NOW, THEREFORE, BE IT RESOLVED BY THE CITY COUNCIL OF ALBERT LEA, MINNESOTA:

Sec. 1. That the conditional use permit for pedestrian bridge #R1144 replacement within the F-1 Floodway District be approved with the following conditions:

1. A Stormwater Pollution and Prevention Plan (SWPPP) be kept on file in part of the CUP approval.

That the motion for the adoption of the foregoing resolution was duly seconded by Councilor , and upon a vote being taken thereon, the following voted in favor thereof: Councilors Christensen, Baker, Herman, Olson, Van Beek, Anderson, and Mayor Murray;

And the following voted against the same: None. Mayor Murray declared the resolution passed.

Introduced and passed this 8<sup>th</sup> day of June, 2026

---

Mayor Rich Murray

Filed and attested this 9<sup>th</sup> day of June, 2026

---

Secretary of the Council

RESOLUTION 26

Introduced by Councilor

RESOLUTION AUTHORIZING THE CITY OF ALBERT LEA TO EXECUTE THE STATE OF MINNESOTA DEPARTMENT OF EMPLOYMENT AND ECONOMIC DEVELOPMENT (DEED) CLEANUP GRANT AGREEMENT NO. 281697 FOR THE FAMILY HOUSING DEVELOPMENT PROJECT (TAPESTRY) - JOB 2611

WHEREAS, the City of Albert Lea desires the financial assistance of the State of Minnesota Department of Employment and Economic Development (DEED) for the Family Housing Development Project on Garfield Avenue (Tapestry); and

WHEREAS, the project involves excavation and disposal of contaminated soil, backfilling, and grading of onsite clean soil throughout the project area for the development of housing.

NOW, THEREFORE, BE IT RESOLVED BY THE CITY COUNCIL OF ALBERT LEA, MINNESOTA:

Sec. 1. That the State of Minnesota DEED Cleanup Agreement No. 281697 Family Housing Development Project is accepted.

Sec. 2. That the Mayor or City Manager are hereby authorized to execute this agreement and any amendments on behalf of the City of Albert Lea.

That the motion for the adoption of the foregoing resolution was duly seconded by Councilor , and upon a vote being taken thereon, the following voted in favor thereof: Councilors Christensen, Baker, Herman, Olson, Van Beek, Anderson and Mayor Murray;

And the following voted against the same: None. Mayor Murray declared the resolution passed.

Introduced and passed this 8<sup>th</sup> day of June, 2026

---

Mayor Rich Murray

Filed and attested this 9<sup>th</sup> day of June, 2026

---

Secretary of the Council

**STATE OF MINNESOTA**  
**GRANT CONTRACT AGREEMENT NO. CCGP-25-0021-Z-FY26**  
**Family Housing Development Project**

This grant contract agreement is between the State of Minnesota, acting through the Department of Employment and Economic Development ("State") and the city of Albert Lea, 221 East Clark Street, Albert Lea, MN, 56007 ("Grantee").

**Recitals**

1. Under [Minn. Stat. § 116J.554](#) the State is empowered to enter into this grant contract agreement.
2. The State is in need of programs that reduce the potential threat of harmful contaminants to public health and the environment, create jobs, increase local property tax, and provide other public benefits by redeveloping polluted sites.
3. Pursuant to [Minn. Stat. § 16B.98](#), the Grantee represents that it is duly qualified and agrees to perform all services described in this grant contract agreement to the satisfaction of the State.

**Grant Contract Agreement**

**1 Term of Grant Contract Agreement**

**1.1 *Effective date:***

December 19, 2025, or the date the State obtains all required signatures under [Minn. Stat. § 16B.98](#), Subd. 5, whichever is later. Per [Minn. Stat. § 16B.98](#), Subd. 7, no payments will be made to the Grantee until this grant contract agreement is fully executed.

**1.2 *Expiration date:***

December 31, 2028, or until all obligations have been satisfactorily fulfilled, whichever occurs first.

**1.3 *Survival of Terms.***

The following clauses survive the expiration or termination of this grant contract agreement:

5. Reporting Requirements; 7. Monitoring and Corrective Action; 10. Liability; 11. State Audits; 12. Government Data Practices and Intellectual Property Rights; 14. Publicity and Endorsement; 15. Governing Law, Jurisdiction and Venue; 17. Data Disclosure; 18. Conflict of Interest; 19. State and Federal Environmental Standards; and 20. Minnesota Business Subsidy Law.

**2 Grantee's Duties**

**2.1 *Duties, Deliverables and Completion Dates.***

The Grantee, who is not a state employee, will perform the following duties and provide the deliverables as outlined below.

**(a)** Comply with required grants management policies and procedures set forth through [Minn. Stat. § 16B.97](#), Subd. 4 (a)(1).

**(b)** Administer these grant funds in accordance with [Minn. Stat. §§ 116J.551](#) through [116J.559](#) and the application submitted on November 3, 2025, for funding for the Family Housing Development Project, which is incorporated into this grant contract agreement and the provisions of this grant contract agreement. Any modification made to the approved application must be approved by the State.

- (c)** It is expected that the site will be cleaned up and redeveloped as proposed in the grant application and upon which funding was based. Any material changes in the cleanup plans and/or development plans for the site must be presented to the State and approved. Promptly notify the State of any proposed material change in the scope of the project as submitted in the grant application, eligible approved Cleanup Costs as defined Section 4.1(c) of this grant contract agreement, or the project’s timeline, which must be approved by the State, prior to implementation.
- (d)** It is also expected that the project will begin as described in the application. To validate that the project has started and eligible work has commenced, a Payment Request, as outlined in Section 4.2(a), must be submitted to the State on or before December 31, 2026, or such a later date requested by the Grantee and approved by the State in writing. If a Payment Request is not submitted, the State’s obligation to fund the Grant may be terminated as described in Section 16.1(b). Invoices must be for approved eligible Cleanup Costs and does not include investigation costs incurred prior to the grant award.
- (e)** Provide evidence to the State prior to the closeout of the grant that the cleanup has been completed and approved by the Minnesota Pollution Control Agency.
- (f)** Adhere to all other requirements of this grant contract agreement.

**2.2 Provisions for Contracts and Sub-grants**

**(a) Contract Provisions**

The Grantee must include in any contract and sub-grant, in addition to provisions that define a sound and complete agreement, such provisions that require contractors and sub-grantees to comply with applicable state and federal laws. Along with such provisions, the Grantee must require that contractors performing work covered by this grant be compliant with all applicable OSHA regulations, especially the federal Hazardous Waste Operations and Emergency Response Standards (29 CFR 1910.120 and 29 CFR 1926.65).

**(b) Ineligible Use of Grant Funds**

The dollars awarded under this grant contract agreement are grant funds and shall only be used by Grantee or awarded by Grantee to third parties as grant funds and cannot take the form of a loan under any circumstance. Grantee shall not use, treat, or convert the grant funds into an interest-bearing loan, a non-interest-bearing loan, a deferred loan, a forgivable deferred loan, or any other type of loan. Further, Grantee shall include in any contract or sub-grant awarding the grant funds to a third party all the provisions and requirements of this grant contract agreement, including the requirement that these dollars are grant funds only and cannot be used, treated, or converted into any type of loan.

**(c) Payment of Contractors and Subcontractors**

The Grantee must provide evidence that all contractors and subcontractors performing work covered by this grant are paid for their work that is satisfactorily completed.

**3 Time**

The Grantee must comply with all the time requirements described in this grant contract agreement. In the performance of this grant contract agreement, time is of the essence.

**4 Consideration and Payment**

**4.1 Consideration**

The State will pay the Grantee under this grant contract agreement as follows:

**(a) Travel Expenses**

Reimbursement for travel and subsistence expenses actually and necessarily incurred by the Grantee as a result of this grant contract agreement are considered administrative in nature and not permitted and will not exceed \$0.00; provided that the Grantee will be reimbursed for travel and subsistence expenses in the same manner and in no greater amount than provided in the current "Commissioner's Plan" promulgated by the Commissioner of Minnesota Management and Budget (MMB). The Grantee will not be reimbursed for travel and subsistence expenses incurred outside Minnesota unless it has received the State's prior written approval for out of state travel. Minnesota will be considered the home state for determining whether travel is out of state. This does not include costs for contractors to complete the activities listed in Section 4.1(c), which may be considered eligible at the discretion of the State.

**(b) Program Income**

Program income generated from grant-funded activities on hand at the end of the grant period must be returned to the State unless the State has approved re-use of the income.

**(c) Eligible Costs**

The following table represents the total approved Cleanup Costs. The Grantee may not use these funds for administrative costs associated with managing this grant or the project this grant is funding. Pursuant to [Minn. Stat. § 116J.552](#), Subd. 2, costs of implementing the response action plan (RAP) incurred before the grant award date may be eligible at the discretion of the State, if the costs were completed after the RAP was approved by the Minnesota Pollution Control Agency and the RAP was approved within 180 days of the application deadline. Costs incurred for the development of the RAP incurred prior to grant award may be considered match eligible at the discretion of the State. Any reimbursement made for services provided prior to the effective date will be governed by the terms of this grant contract agreement.

Grant Eligible Activities	Amount
Investigation (Match Only)	\$16,523
Contaminated Soil Excavation, Transportation, and Disposal	\$180,256
Clean Fill Import	\$83,196
Environmental Oversight and Reporting	\$76,675
Total	\$356,650

**(d) Total Obligation**

The total obligation of the State for all compensation and reimbursements to the Grantee under this grant contract agreement will not exceed \$267,487.

In accordance with [Minn. Stat. § 116J.554](#), Subd. 1, the grant may pay for up to 75% of the eligible costs for a qualifying site. This requires a local match of at least 25%. For the purpose of this project, based on the budget above, the local match portion is at least \$89,163. Of the total match requirement, 12% of the cleanup costs as defined by [Minn. Stat. § 116J.552](#), Subd. 2 must come from the municipality's general fund, a property tax levy for that purpose, or other unrestricted money available to the municipality. The rest of the local match may be paid with tax increments, regional, state, or federal money available for the redevelopment of brownfields or any other money available to the municipality.

## 4.2 **Payment**

### **(a) Invoices**

The State will disburse funds to the Grantee pursuant to this Contract, based upon payment requests submitted by the Grantee and reviewed and approved by the State. Payment requests must be accompanied by supporting invoices for the activities defined in Section 4.1(c) of this grant contract agreement. The amount of grant funds requested by the Grantee cannot exceed 75% of the total approved Cleanup Costs incurred by the Grantee as supported by invoices. The State will provide payment request forms. Every effort should be made to submit invoices within the same fiscal year the costs were incurred. To ensure that all funds are drawn prior to the expiration date of the grant, the final payment request must be received at least 30 days prior to the grant-term expiration date.

### **(b) Unexpended Funds**

Any grant funds not reimbursed to the Grantee shall revert back to the State.

## 4.3 **Contracting and Bidding Requirements**

Per Minn. Stat. § 471.345, grantees that are municipalities as defined in Subd. 1 must follow the law.

**(a)** Prevailing wage rates are required to be paid on an economic development project site if that project receives or will be receiving state financial assistance in the form of a grant where a single business receives \$200,000 or more of the grant proceeds, a loan or the guaranty or purchase of a loan if a single business receives \$500,000 or more of the loan proceeds, or certain tax incentives, per Minn. Stat. § 116J.871. For economic development projects subject to the prevailing wage requirements in Minn. Stat. § 116J.871, Grantee must ensure that Grantee and all contractors and subcontractors comply with applicable prevailing wage requirements including submitting all required certified payroll records, as described in Exhibit A, "Prevailing Wage Certification – Minn. Stat. § 116J.871," to the following email address: [wagedata.deed@state.mn.us](mailto:wagedata.deed@state.mn.us).

**(b)** The grantee must not contract with vendors who are suspended or debarred in MN: <https://mn.gov/admin/osp/government/suspended-debarred/>.

## 5 **Reporting Requirements**

The Grantee must submit to the State annual reports on the use of grant funds and the progress of the Project covering July 1<sup>st</sup> through June 30<sup>th</sup> of each year. Each annual report must be received by the State no later than July 25<sup>th</sup> of each year. The annual report must identify specific Project goals listed in the application and quantitatively and qualitatively measure the progress of such goals. Grant payments shall not be made on grants, or subsequent grant awards made to the Grantee, with past due reports. In addition, the Grantee shall submit a final annual report. The State will provide annual reporting form.

## 6 **Conditions of Payment**

All services provided by the Grantee under this grant contract agreement must be performed to the State's satisfaction, as determined at the sole discretion of the State's Authorized Representative and in accordance with all applicable federal, state and local laws, ordinances, rules and regulations. The Grantee will not receive payment for work found by the State to be unsatisfactory or performed in violation of federal, state or local law.

## 7 **Monitoring and Corrective Action**

The Grantee agrees to permit monitoring by the State to determine grant contract agreement performance and compliance with grant contract agreement provisions. The Grantee further agrees to cooperate with the State in performing and completing such monitoring activities and the Grantee agrees to implement and

comply with such corrective action as is proposed by the State. The Grantee must provide any financial records, timesheets or other supporting documentation, upon the request of the State.

## **8 Authorized Representative**

The State's Authorized Representative is Angela Oldson, Project Manager, 180 E 5<sup>th</sup> Street, Suite 1200, St. Paul, MN, 55101, 651-259-7448, [angela.oldson@state.mn.us](mailto:angela.oldson@state.mn.us), or his/her successor, and has the responsibility to monitor the Grantee's performance and the authority to accept the services provided under this grant contract agreement. If the services are satisfactory, the State's Authorized Representative will certify acceptance on each invoice submitted for payment.

The Grantee's Authorized Representative is Steven Jahnke, City Engineer and Director of Public Works, 221 East Clark Street, Albert Lea, MN, 56007-2421, (507) 377-4325, [sjahnke@ci.albertlea.mn.us](mailto:sjahnke@ci.albertlea.mn.us). If the Grantee's Authorized Representative changes at any time during this grant contract agreement, the Grantee must immediately notify the State.

## **9 Assignment, Amendments, Adjustments, Waiver and Grant Contract Agreement Complete**

### **9.1 Assignment**

The Grantee shall neither assign nor transfer any rights or obligations under this grant contract agreement without the prior written consent of the State, approved by the same parties who executed and approved this grant contract agreement or their successors in office.

### **9.2 Amendments**

Any amendments to this grant contract agreement, with the exception of Grant Adjustment Notices (GANs), must be in writing and will not be effective until it has been executed and approved by the same parties who executed and approved the original grant contract agreement or their successors in office.

### **9.3 Grant Adjustment Notices (GANs)**

GANs must be approved by the State in writing and may require a written change request by the Grantee. A GAN may be used for non-substantive changes that do not affect grant requirements, including, but not limited to, changing grant status activity, or changing budget amounts within approved grant eligible activities that do not increase the awarded value. All other changes require formal amendment as stated in Section 9.2.

### **9.4 Waiver**

If the State fails to enforce any provision of this grant contract agreement, that failure does not waive the provision or the State's right to enforce it.

### **9.5 Grant Contract Agreement Complete**

This grant contract agreement contains all negotiations and agreements between the State and the Grantee. No other understanding regarding this grant contract agreement, whether written or oral, may be used to bind either party.

## **10 Liability**

Subject to the provisions and limitations of [Minn. Stat. § 466](#), the Grantee must indemnify, save and hold the State, its agents and employees harmless from any claims or causes of action, including attorney's fees incurred by the State, arising from the performance of this grant contract agreement by the Grantee or the Grantee's agents, employees or independent contractors. This clause will not be construed to bar any legal remedies the Grantee may have for the State's failure to fulfill its obligations under this grant contract agreement.

## 11 State Audits

Under [Minn. Stat. § 16B.98](#), Subd.8, the Grantee's books, records, documents, and accounting procedures and practices of the Grantee or other party relevant to this grant contract agreement or transaction are subject to examination by the Commissioner of Administration, by the State granting agency and/or the State Auditor or Legislative Auditor, as appropriate, for a minimum of six years from the end of this grant contract agreement, receipt and approval of all final reports, or the required period of time to satisfy all state and program retention requirements, whichever is later.

The Grantee shall maintain adequate financial records consistent with generally accepted accounting principles. The Grantee shall submit accounting system records that track the use of grant proceeds and all matching funds by eligible Cleanup Costs for each year in which grant disbursements and expenditures were made. The records shall reflect both expenditures and revenues and shall be submitted after all grant proceeds and matching funds have been expended or at the State's request.

## 12 Government Data Practices and Intellectual Property Rights

### 12.1 *Government Data Practices*

The Grantee and State must comply with the Minnesota Government Data Practices Act, [Minn. Stat. Ch. 13](#), as it applies to all data provided by the State under this grant contract agreement, and as it applies to all data created, collected, received, stored, used, maintained or disseminated by the Grantee under this grant contract agreement. The civil remedies of [Minn. Stat. § 13.08](#) apply to the release of the data referred to in this clause by either the Grantee or the State. If the Grantee receives a request to release the data referred to in this Clause, the Grantee must immediately notify the State. The State will give the Grantee instructions concerning the release of the data to the requesting party before the data is released. The Grantee's response to the request shall comply with applicable law.

### 12.2 *Intellectual Property Rights*

The Grantee represents and warrants that Grantee's intellectual property used in the performance of this grant contract agreement does not and will not infringe upon any intellectual property rights of other persons or entities. Notwithstanding Clause 10, the Grantee will indemnify; defend, to the extent permitted by the Attorney General; and hold harmless the State, at the Grantee's expense, from any action or claim brought against the State to the extent that it is based on a claim that all or part of Grantee's intellectual property used in the performance of this grant contract agreement infringe upon the intellectual property rights of others. The Grantee will be responsible for payment of any and all such claims, demands, obligations, liabilities, costs and damages, including but not limited to, attorney fees. If such a claim or action arises, or in the Grantee's or the State's opinion is likely to arise, the Grantee must, at the State's discretion, either procure for the State the right or license to use the intellectual property rights at issue or replace or modify the allegedly infringing intellectual property as necessary and appropriate to obviate the infringement claim. This remedy of the State will be in addition to and not exclusive of other remedies provided by law.

## 13 Workers Compensation

The Grantee certifies that it is in compliance with [Minn. Stat. § 176.181](#), Subd. 2, pertaining to workers' compensation insurance coverage. The Grantee's employees and agents will not be considered State employees. Any claims that may arise under the Minnesota Workers' Compensation Act on behalf of these employees and any claims made by any third party as a consequence of any act or omission on the part of these employees are in no way the State's obligation or responsibility.

## 14 Publicity and Endorsement

### 14.1 **Publicity**

Any publicity regarding the subject matter of this grant contract agreement must identify the State as the sponsoring agency. For purposes of this provision, publicity includes notices, informational pamphlets, press releases, research, reports, signs and similar public notices prepared by or for the Grantee individually or jointly with others, or any subcontractors, with respect to the program, publications or services provided resulting from this grant contract agreement. For DEED logos, please contact the State's Authorized Representative.

### 14.2 **Endorsement**

The Grantee must not claim that the State endorses its products or services.

## 15 Governing Law, Jurisdiction and Venue

Minnesota law, without regard to its choice-of-law provisions, governs this grant contract agreement. Venue for all legal proceedings out of this grant contract agreement, or its breach, must be in the appropriate state or federal court with competent jurisdiction in Ramsey County, Minnesota.

## 16 Termination

### 16.1 **Termination by the State**

**(a) Without Cause.** The State may terminate this grant contract agreement without cause, upon 30 days' written notice to the Grantee. Upon termination, the Grantee will be entitled to payment, determined on a pro rata basis, for services satisfactorily performed.

**(b) With Cause.** The State may immediately terminate this grant contract agreement if the State finds that there has been a failure to comply with the provisions of this grant contract agreement, that reasonable progress has not been made or that the purposes for which the funds were granted have not been or will not be fulfilled. The State may take action to protect the interests of the State of Minnesota, including the refusal to disburse additional funds and requiring the return of all or part of the funds already disbursed.

### 16.2 **Termination by the Commissioner of Administration**

The Commissioner of Administration may immediately and unilaterally cancel this grant contract agreement if further performance under the agreement would not serve agency purposes or is not in the best interest of the State.

### 16.3 **Termination for Insufficient Funding**

The State may immediately terminate this grant contract agreement if:

**(a)** It does not obtain funding from the Minnesota Legislature.

**(b)** Or, if funding cannot be continued at a level sufficient to allow for the payment of the services covered here. Termination must be by written notice to the Grantee. The State is not obligated to pay for any services that are provided after notice and effective date of termination. However, the Grantee will be entitled to payment, determined on a pro rata basis, for services satisfactorily performed to the extent that funds are available. The State will not be assessed any penalty if the contract is terminated because of the decision of the Minnesota Legislature or other funding source, not to appropriate funds. The State must provide the Grantee notice of the lack of funding within a reasonable time of the State's receiving that notice.

### 16.4 **Termination for Criminal Conviction**

As required by Minn. Stat. § 16B.991, subd. 1, the Grant Agreement will immediately be terminated if the recipient is convicted of a criminal offense relating to a state grant agreement.

**17 Data Disclosure**

Under [Minn. Stat. § 270C.65](#), Subd. 3, and other applicable law, the Grantee consents to disclosure of its social security number, federal employer tax identification number, and/or Minnesota tax identification number, already provided to the State, to federal and state tax agencies and state personnel involved in the payment of state obligations. These identification numbers may be used in the enforcement of federal and state tax laws which could result in action requiring the Grantee to file state tax returns and pay delinquent state tax liabilities, if any.

**18 Conflicts of Interest**

The State will take steps to prevent individual and organizational conflicts of interest in reference to Grantees per [Minn. Stat. § 16B.98](#) and Department of Administration, Office of Grants Management, Policy Number 08-01 [Conflict of Interest Policy for State Grant-Making](#) (Current Policies tab). When a conflict of interest concerning State grant-making is suspected, disclosed or discovered, transparency shall be the guiding principle in addressing it.

In cases where a potential or actual individual or organizational conflict of interest is suspected, disclosed, or discovered by the Grantee throughout the life of the grant contract agreement, they must immediately notify the State for appropriate action steps to be taken, as defined above.

The Grantee must complete a Conflict-of-Interest Disclosure Form.

**19 State and Federal Environmental Standards**

The Grantee must provide evidence that work performed under this grant contract agreement complies with state and federal environmental standards. An approval from the Minnesota Pollution Control Agency or other appropriate state or federal agency is required upon completion of the cleanup activities.

**20 Minnesota Business Subsidy Law**

The Grantee must comply, if appropriate, with the Minnesota Business Subsidy Law, [Minn. Stat. §§ 116J.993](#) through [116J.995](#).

*(The rest of this page is left intentionally blank)*

1. STATE ENCUMBRANCE VERIFICATION

Individual certifies that funds have been encumbered as required by Minn. Stat. § 16A.15.

Signed: Robin Culbertson

Date: 01/09/26

SWIFT Contract/PO No(s): 281697 PR 99757 PO 3-632934

2. GRANTEE

The Grantee certifies that the appropriate person(s) has executed the grant contract agreement on behalf of the Grantee as required by applicable articles, bylaws, resolutions, or ordinances.

By: \_\_\_\_\_

Title: Mayor

Date: \_\_\_\_\_

By: \_\_\_\_\_

Title: City Manager

Date: \_\_\_\_\_

3. STATE OF MINNESOTA: DEPARTMENT OF EMPLOYMENT AND ECONOMIC DEVELOPMENT

By: \_\_\_\_\_  
(WITH DELEGATED AUTHORITY)

Title: Deputy Commissioner

Date: \_\_\_\_\_

Distribution:  
Agency  
Grantee  
State's Authorized Representative



To: Minnesota Department of Labor and Industry  
Prevailing-wage compliance unit  
443 Lafayette Road N.  
St. Paul, MN 55155

Re: Prevailing-wage certification – Minnesota Statutes § 116J.871

\_\_\_\_\_ is a recipient of financial assistance from the \_\_\_\_\_ for the project identified below.

As required by Minn. Stat. § 116J.871, subd. 2(a), \_\_\_\_\_ hereby certifies to the commissioner of the Department of Labor and Industry, that laborers and mechanics at the project site during construction, installation, remodeling or repairs for which the financial assistance will be provided, in whole or part, will be paid the prevailing-wage rate as defined in Minn. Stat. § 177.42, subd. 6. Prevailing wages paid to laborers and mechanics at the project site shall comply with the prevailing-wage rates determined for \_\_\_\_\_ county, Minnesota.

\_\_\_\_\_ understands that failure to pay prevailing wages is a misdemeanor and that each day of violation is a separate offense under Minn. Stat. § 116J.871, subd. 3.

Project name: \_\_\_\_\_  
(Insert project name)

Project start date: \_\_\_\_\_  
(Insert project start date)

Project site address: \_\_\_\_\_  
(Insert project site address)

Financial assistance contract number: \_\_\_\_\_  
(Insert financial assistance contract number)

By: \_\_\_\_\_ Signature: \_\_\_\_\_  
(Print name of authorized representative) (Signature of authorized representative)

Its: \_\_\_\_\_ Date: \_\_\_\_\_  
(Authorized representative's title) (Date signed and certified)

## Information for recipients

Recipients must ensure all laborers and mechanics at the project site during construction, installation, remodeling or repairs for which the financial assistance from a state agency or allocating agency will be provided is performed under contracts that specifically include the prevailing-wage rate requirements of the Minnesota Prevailing Wage Act (“MPWA”), Minnesota Statutes sections 177.41-.44 and Minnesota Rules, sections 5200.1000-.1120.

Recipients also must ensure that contractors and their subcontractors will comply with the requirements of the MPWA, including recordkeeping, completion and submission of certified payroll reports, posting and contract requirements and the requirement that laborers and mechanics at the project site during construction, installation, remodeling or repairs for which the financial assistance will be provided are paid the applicable prevailing-wage rate(s) for each classification of work they perform. These requirements and enforcement provisions are set forth at Minn. Stat. § 116J.871, subd. 2(a).

In accordance with the MPWA and because the commissioner, pursuant to Minn. Stat. § 177.30(a)(7), has deemed certain payroll information necessary and appropriate, recipients must also ensure that each employer performing work at the project site during construction, installation, remodeling or repairs for which financial assistance from a state agency is provided will prepare, maintain as required, and provide to the Department of Labor and Industry upon request, certified payroll reports with respect to the wages and benefits paid to employees specifying for each employee: the employee’s name; prevailing-wage job classifications; hours worked each day; total hours; rates of pay; gross amount earned; each deduction for taxes; total deductions; net pay per week; dollars contributed per hour for each benefit, including name and address of administrator; benefit account number; and telephone number for health and welfare, vacation or holiday, apprenticeship training, pension, and other benefit programs.

These same certified payroll records must be submitted to the contracting authority no more than 14 days after the end of each pay period and retained by the employer for a minimum of three years after the final payment is made on the project. Minn. Stat. §§ 177.30 (a)(7), 177.43, subd. 3. A sample certified payroll form is available at [dli.mn.gov/sites/default/files/pdf/pw\\_certified\\_payroll\\_form.pdf](https://dli.mn.gov/sites/default/files/pdf/pw_certified_payroll_form.pdf). The state agency or allocating agency awarding the financial assistance is considered the contracting authority. Minn. Stat. § 116J.871, subd. 2(b).

Recipients of financial assistance from a state agency or allocating agency should contact the Department of Labor and Industry for applicable prevailing-wage rates and guidance on how to comply with prevailing wage-requirements in section 116J.871 and the MPWA:

Division of Labor Standards

Karen Bugar, State Program Administrative Director

443 Lafayette Road N, St. Paul, MN 55155

651-284-5091 or [dli.prevwage@state.mn.us](mailto:dli.prevwage@state.mn.us)

**Email a completed copy of this form to [dli.prevwage@state.mn.us](mailto:dli.prevwage@state.mn.us) or mail a copy of this form to the Department of Labor and Industry at the address on page 1 of this form. A copy should also be submitted to the state agency or allocating agency awarding the financial assistance.**

RESOLUTION 26-

Introduced by Councilor

RESOLUTION CALLING PUBLIC HEARING FOR DECLARING PROPERTY WITHOUT  
PUBLIC PURPOSE AND WAIVING PLANNING COMMISSION REVIEW (PORTION OF  
MORIN PARK)

WHEREAS, the City of Albert Lea ("City") currently owns Property at 222 St. Mary Avenue (Morin Park), and is legally described as:

PID: 34.601.1300

Lots 18 and 19, Original Plat of the City of Albert Lea, as the same is platted and recorded. Office of the County Recorder, Freeborn County, Minnesota.

WHEREAS, the City has granted the Minnesota Department of Transportation a permanent easement for highway purposes for a small portion of the southwest corner of said property herein legally described as

That part of the Northeast Quarter of the Southeast Quarter of Section 8, Township 102 North, Range 21 West, also known as Blocks 18 and 19, THE VILLAGE OF ALBERT LEA, shown as Parcel 49 on the Minnesota Department of Transportation Right-of-Way Plat Numbered 24-13 as the same is on file and of record in the office of the County Recorder in and for Freeborn County, Minnesota, and

WHEREAS, the City does not currently nor does it intend to use the Property for any public purpose, and the proposed use of the Property is similar to or will not interfere with the property uses, and, therefore, the sale of the Property has no relationship to the comprehensive municipal plan; and

NOW, THEREFORE, BE IT RESOLVED BY THE CITY COUNCIL OF ALBERT LEA, MINNESOTA:

Sec. 1. That the proposed uses of the Property adhere to the comprehensive municipal plan, and therefore, the Council waives the planning commission review, in accordance with Minn. Stat. § 462.356, subd. 2.

Sec. 2. The Property has no further public purpose that requires City ownership.

Sec. 3. That a public hearing shall be held on the 13<sup>th</sup> day of July, 2026 at 7:00 p.m. during the City Council meeting, and the City shall give mailed and published public hearing notice as required of City Charter Sec. 12.05, City Code Sec. 2.12, and as required by law, allowing the Council to proceed with the disposal of the Property.

That the motion for the adoption of the foregoing resolution was duly seconded by Councilor , and upon a vote being taken thereon, the following voted in favor thereof: Councilors Christensen, Baker, Herman, Olson, Van Beek, Anderson, and Mayor Murray;

And, the following voted against the same: None. Mayor Murray declared the motion passed.

Introduced and passed this 8<sup>th</sup> day of June, 2026

---

Mayor Rich Murray

Filed and attested this 9<sup>th</sup> day of June, 2026

---

Secretary of the Council

RESOLUTION 26

Introduced by Councilor

RESOLUTION AUTHORIZING EXECUTION OF MNDNR MYRE-BIG ISLAND STATE PARK  
SEWER COLLECTION SYSTEM DESIGN AND SERVICE COOPERATIVE AGREEMENT –  
JOB 2619

WHEREAS, the MNDNR desires the City provide sanitary sewer service to the Myre-  
Big Island State Park; and

WHEREAS, the MNDNR and City of Albert Lea have drafted a Cooperative Agreement  
which provides  
the terms for this service.

NOW, THEREFORE, BE IT RESOLVED BY THE CITY COUNCIL OF ALBERT LEA,  
MINNESOTA:

Sec. 1. That the State of Minnesota DNR Cooperative Agreement is accepted.

Sec. 2. That the Mayor or City Manager are hereby authorized to execute this  
agreement and any amendments on behalf of the City of Albert Lea.

That the motion for the adoption of the foregoing resolution was duly seconded by Councilor ,  
and upon a vote being taken thereon, the following voted in favor thereof: Councilors  
Christensen, Baker, Herman, Olson, Van Beek, Anderson and Mayor Murray;

And the following voted against the same: None. Mayor Murray declared the resolution  
passed.

Introduced and passed this 8<sup>th</sup> day of June 2026

---

Mayor Rich Murray

Filed and attested this 9<sup>th</sup> day of June 2026

---

Secretary of the Council



# State of Minnesota Cooperative Agreement

## MYRE-BIG ISLAND STATE PARK SEWER COLLECTION SYSTEM DESIGN AND SERVICE COOPERATIVE AGREEMENT BETWEEN THE STATE OF MINNESOTA AND CITY OF ALBERT LEA

This Agreement is between the State of Minnesota, acting through its Commissioner of the Department of Natural Resources (“State”) and the City of Albert Lea, (“City”).

### Recitals

The Commissioner of Natural Resources has the authority, duty, and responsibility under Minnesota Statutes Section 85.012, Subd. 27 to establish, develop, maintain and operate Myre-Big Island State Park.

The State and County are authorized under Minnesota Statutes Section 471.59, to enter into agreements to jointly or cooperatively exercise common power.

The State owns land described as: Myre-Big Island State Park in Sec. 7, 18, 19, in T102N, R20W, and Sec. 11, 12, 13, 14, 23, 24, in T102N, R21W, Freeborn County, as shown the Map, referenced as **Exhibit A**.

The City owns and operates a sanitary sewer collection system and operates a wastewater treatment facility, hereinafter referred to as the “City Sewer System”.

The State proposes to decommission its existing sewer collection system and wastewater treatment ponds in Myre-Big-Island State Park and construct a new sewer collection system connected to the City of Albert Lea’s sewer system for transport, treatment, and proper disposal. Said new sewer collection system is hereinafter referred to as the “Park Sewer System”, as shown in the Map and referenced as **Exhibit A**.

The State and the City have determined that connecting the proposed Park Sewer System to the City Sewer System is of mutual and public benefit.

The State has completed the Final Plans for the Park Sewer System which have been approved by the City and are referenced as **Exhibit B**.

The City is prepared to permit the State to connect the Park Sewer System to the City Sewer System at the manhole at the intersection of County State Aid Highway 46 and County State Aid Highway 38, as identified in the Plans referenced as **Exhibit B**.

Upon completion, the administration, operations and maintenance of the Park Sewer System shall be the sole responsibility of the State.

A copy of the City Council resolution authorizing the City to enter into this agreement has been provided as shown in **Exhibit C**.

## **Agreement**

### **1. Term of Agreement**

- 1.1 Effective Date: July 1, 2026, or the date the State obtains all required signatures under Minn. Stat. § 16C.05, subd. 2, whichever is later.
- 1.2 Expiration Date: June 30, 2061, or until all obligations have been satisfactorily fulfilled, whichever occurs first. This agreement shall renew at the end of the term for an additional five (5) year period unless a party gives three (3) months' written notice to the other party to terminate the agreement. This agreement shall continue to automatically renew at the end of each five (5) year period unless the required notice is given.

### **2. Agreement between the Parties**

#### **2.1 State's Duties and Responsibilities. The State shall:**

- a. Solely own and be responsible for the cost of design, construction, operation and maintenance of the Park Sewer System, including all pipe, valves, air release valves, structures, odor control system, sampling manhole, and other necessary components.
- b. Bid and administer all construction contracts for this project, as well as provide all construction engineering, staking, materials testing, record keeping and construction inspection.
- c. Comply with all applicable state and federal environmental laws and regulations, and will obtain any and all necessary environmental reviews, licenses or clearances under any federal or state law or regulation in connection with the construction and operation of the Park Sewer System.
- d. Comply with all applicable requirements of Chapter 44, Article III of the City Municipal Code as published.
- e. Permit the City to review and comment on any major alterations to the Park Sewer System proposed by the State during the term of this Agreement.
- f. Use the Park Sewer System solely for the benefit of the park and its visitors, no other connections to or use of the Park Sewer System will be allowed without the prior written approval of the City.
- g. The total maximum allowable flow from the Park System to the City System shall be:

Peak Day: 10,500 gallons per day

Peak Hour: 180 gallons per minute

- h. Pay the monthly base service charge and consumption fee as set forth in Article 2.1 for as long as the Park System discharges to the City System.
- i. Pay the City the standard sewer access fee, at the time of connection, as set forth in Article 2.1.
- j. Be solely responsible for removal of its infrastructure and restoration of the affected City property to the satisfaction of the City Engineer, and at no cost to the City, upon termination or cancellation of this agreement.

## **2.2 City's Duties and Responsibilities. The City shall:**

- a. Permit the State to discharge sewage flow, subject to the restrictions contained herein, at the connection point with the City Sewer System, as shown on **Exhibit A**. The City will be responsible for treating the wastewater flow from the Park Sewer System at the City Wastewater Treatment Facility.
- b. Be permitted to review and approve any major alterations to the Park Sewer System proposed by the State during the term of this Agreement.
- c. Comply with all applicable local, state and federal environmental laws and regulations, and will obtain any and all necessary environmental reviews, licenses or clearances under any federal or state law or regulation in connection with the transport, treatment, and disposal of sewage from the Park Sewer System beginning at the point of connection to the City Sewer System.
- d. Charge the State a monthly Base Service Charge and Consumption Fee as established in the City's published Fee Schedule for Sanitary Sewer Billing Rates. Future adjustments in the monthly Base Service Charge and Consumption Fee shall be identical with those adjustments for other comparable customers in the City. A metering system installed at the Park Sewer System will be used for calculating monthly volumes to be billed by the City. The Base Service Charge will be for a 2" meter.
- e. Charge the State the same standard sewer access fee as other residential customers in the City as established in the City's published Fee Schedule at the time of connection. Each connection point shown on **Exhibit A** will be assessed a sewer access fee.

## **3. Funding**

The State shall provide funding for its responsibilities under Article 2.1 above through the standard internal purchasing process including, but not limited to, a separate requisition in which funds will be encumbered. The total obligation of the State is also limited to the amount of funds legislatively appropriated and administratively allocated to this Project.

## **4. Authorized Representatives**

The State's Authorized Representative is Carter Vogel, Myre-Big Island State Park Manager, Minnesota Department of Natural Resources, 19499 780<sup>th</sup> Avenue, Albert Lea, MN 56007, 507-668-7061, [carter.vogel@state.mn.us](mailto:carter.vogel@state.mn.us) or their successor.

The City's Authorized Representative is Steven, Jahnke, Albert Lea Public Works Director, City of Albert Lea, 221 East Clark Street, Albert Lea, MN 56007, 507-377-4325, [sjahnke@ci.albertlea.mn.us](mailto:sjahnke@ci.albertlea.mn.us) or their successor.

## **5. Assignment, Amendments, Waiver, and Contract Complete.**

5.1 Assignment. The City may neither assign nor transfer any rights or obligations under this Agreement without the prior consent of the State and a fully executed assignment agreement, executed and approved by the authorized parties or their successors.

5.2 Amendments. Any amendment to this Agreement must be in writing and will not be effective until it has been executed and approved by the authorized parties or their successors.

5.3 Waiver. If the State fails to enforce any provision of this Agreement, that failure does not waive the provision or its right to enforce it.

5.4 Contract Complete. This Agreement contains all negotiations and agreements between the State and the City. No other understanding regarding this Agreement, whether written or oral, may be used to bind either party.

## **6. Liability**

Each party agrees that it will be responsible for its own acts and the results thereof to the extent authorized by law and shall not be responsible for the acts of the other party and the results thereof. The State's liability shall be governed by the provisions of the Minnesota Tort Claims Act, Minnesota Statutes Section 3.736, and other applicable law. The City's liability shall be governed by Minnesota Statutes Sections 466.01 - 466.15, and other applicable law.

## **7. State Audits.**

Under Minn. Stat. § 16C.05, subd. 5, the City's books, records, documents, and accounting procedures and practices relevant to this Agreement are subject to examination by the State, the State Auditor, or Legislative Auditor, as appropriate, for a minimum of six years from the expiration or termination of this Agreement.

## **8. Government Data Practices.**

The City and State must comply with the Minnesota Government Data Practices Act, Minn. Stat. Ch. 13, (or, if the State contracting party is part of the Judicial Branch, with the Rules of Public Access to Records of the Judicial Branch promulgated by the Minnesota Supreme Court as the same may be amended from time to time) as it applies to all data provided by the State under this Agreement, and as it applies to all data created, collected, received, stored, used, maintained, or disseminated by the City under this Contract. The civil remedies of Minn. Stat. § 13.08 apply to the release of the data governed by the Minnesota Government Practices Act, Minn. Stat. Ch. 13, by either the City or the State.

If the City receives a request to release the data referred to in this clause, the City must immediately notify and consult with the State's Authorized Representative as to how the City should respond to the request. The City's response to the request shall comply with applicable law.

## **9. Publicity and Endorsement.**

**9.1 Publicity.** Any publicity regarding the subject matter of this Contract must identify the State as the sponsoring agency and must not be released without prior written approval from the State's Authorized Representative. For purposes of this provision, publicity includes notices, informational pamphlets, press releases, information posted on corporate or other websites, research, reports, signs, and similar public notices prepared by or for the City individually or jointly with others, or any subcontractors, with respect to the program, publications, or services provided resulting from this Contract.

All publicity shall be provided in an accessible format per Minnesota Statute 16E.03, sub. 9. State of Minnesota guidelines for creating accessible electronic documents can be found at the following URL: <https://mn.gov/mnit/programs/accessibility/>.

**9.2 Endorsement.** The City must not claim that the State endorses its products or services.

## **10. Venue**

Venue for all legal proceedings out of this Agreement, or its breach, must be in the appropriate state or federal court with competent jurisdiction in Ramsey County, Minnesota.

## **11. Termination**

**11.1 Termination.** This Agreement may be cancelled by the State at any time, with or without cause, or as necessary as provided in Article 3, upon thirty (30) days written notice to the City. This Agreement may also be cancelled by the City under the conditions set forth by Article 1.2 above or at any time with cause upon thirty (30) days written notice to the State.

**11.2 Termination for Insufficient Funding.** The State may immediately terminate this Agreement if it does not obtain funding from the Minnesota Legislature, or other funding source; or if funding cannot be continued at a level sufficient to allow for the payment of the services covered here. Termination must be by written or fax notice to the City. The State is not obligated to pay for any services that are provided after notice and effective date of termination. However, the City will be entitled to payment, determined on a pro rata basis, for services satisfactorily performed to the extent that funds are available. The State will not be assessed any penalty if the agreement is terminated because of the decision of the Minnesota Legislature, or other funding source, not to appropriate funds. The State must provide the City notice of the lack of funding within a reasonable time of the State's receiving that notice.

## 12. Force Majeure

Neither party shall be responsible to the other or considered in default of its obligations within this Agreement to the extent that performance of any such obligations is prevented or delayed by acts of God, war, riot, disruption of government, or other catastrophes beyond the reasonable control of the party unless the act or occurrence could have been reasonably foreseen and reasonable action could have been taken to prevent the delay or failure to perform. A party relying on this provision to excuse performance must provide the other party prompt written notice of inability to perform and take all necessary steps to bring about performance as soon as practicable.

## 13. E-Verify Certification (in accordance with Minn. Stat. § 16C.075).

For services valued in excess of \$50,000, the City certifies that as of the date of services performed on behalf of the State, City and all its subcontractors will have implemented or be in the process of implementing the federal E-Verify Program for all newly hired employees in the United States who will perform work on behalf of the State. The City is responsible for collecting all subcontractor certifications and may do so utilizing the E-Verify Subcontractor Certification Form available at <http://www.mmd.admin.state.mn.us/doc/EVerifySubCertForm.doc>. All subcontractor certifications must be kept on file with Contractor and made available to the State upon request.

14. Exhibits. The following Exhibits are attached and incorporated into this Contract. In the event of a conflict between the terms of this Contract and its Exhibits, or between Exhibits, the order of precedence is first the Contract, and then in the following order:

**Exhibit A: Map of State Park Ownership and Park Sewer System Layout**

**Exhibit B: Final Plans for the Myre Sewer Improvements** (includes CSAH 38 right-of-way)

**Exhibit C: City Council Meeting Minutes/Resolution** (supporting this agreement)

[The Balance OF This Page is Left Intentionally Blank]

**1. State Encumbrance Verification**

*Individual certifies that funds have been encumbered as required by Minn. Stat. §§ 16A.15 and 16C.05*

Print Name: \_\_\_\_\_

Signature: \_\_\_\_\_

Title: \_\_\_\_\_ Date: \_\_\_\_\_

SWIFT Contract No. \_\_\_\_\_

**2. City of Albert Lea**

Print Name: \_\_\_\_\_

Signature: \_\_\_\_\_

Title: \_\_\_\_\_ Date: \_\_\_\_\_

**City of Albert Lea**

Print Name: \_\_\_\_\_

Signature: \_\_\_\_\_

Title: \_\_\_\_\_ Date: \_\_\_\_\_

**3. State Agency**

*With delegated authority*

Print Name: \_\_\_\_\_

Signature: \_\_\_\_\_

Title: \_\_\_\_\_ Date: \_\_\_\_\_

**4. Commissioner of Administration**

*As delegated to The Office of State Procurement*

Print Name: \_\_\_\_\_

Signature: \_\_\_\_\_

Title: \_\_\_\_\_ Date: \_\_\_\_\_

Admin ID: \_\_\_\_\_

RESOLUTION 26

Introduced by Councilor

RESOLUTION AUTHORIZING EXECUTION OF MNDNR MYRE-BIG ISLAND STATE  
PARK SEWER COLLECTION SYSTEM JOINT POWERS AGREEMENT – JOB 2619

WHEREAS, the MNDNR desires the City provide sanitary sewer service to the Myre-Big Island State Park; and

WHEREAS, the MNDNR and City of Albert Lea have drafted a Joint Powers Agreement which provides the terms for City locate and emergency response service.

NOW, THEREFORE, BE IT RESOLVED BY THE CITY COUNCIL OF ALBERT LEA, MINNESOTA:

Sec. 1. That the State of Minnesota DNR Joint Powers Agreement is accepted.

Sec. 2. That the Mayor or City Manager are hereby authorized to execute this agreement and any amendments on behalf of the City of Albert Lea.

That the motion for the adoption of the foregoing resolution was duly seconded by Councilor , and upon a vote being taken thereon, the following voted in favor thereof: Councilors Christensen, Baker, Herman, Olson, Van Beek, Anderson and Mayor Murray;

And the following voted against the same: None. Mayor Murray declared the resolution passed.

Introduced and passed this 8<sup>th</sup> day of June 2026

---

Mayor Rich Murray

Filed and attested this 9<sup>th</sup> day of June 2026

---

Secretary of the Council



# State of Minnesota Cooperative Agreement

## MYRE-BIG ISLAND STATE PARK SEWER COLLECTION SYSTEM DESIGN AND SERVICE COOPERATIVE AGREEMENT BETWEEN THE STATE OF MINNESOTA AND CITY OF ALBERT LEA

This Agreement is between the State of Minnesota, acting through its Commissioner of the Department of Natural Resources (“State”) and the City of Albert Lea, (“City”).

### Recitals

The Commissioner of Natural Resources has the authority, duty, and responsibility under Minnesota Statutes Section 85.012, Subd. 27 to establish, develop, maintain and operate Myre-Big Island State Park.

The State and County are authorized under Minnesota Statutes Section 471.59, to enter into agreements to jointly or cooperatively exercise common power.

The State owns land described as: Myre-Big Island State Park in Sec. 7, 18, 19, in T102N, R20W, and Sec. 11, 12, 13, 14, 23, 24, in T102N, R21W, Freeborn County, as shown the Map, referenced as **Exhibit A**.

The City owns and operates a sanitary sewer collection system and operates a wastewater treatment facility, hereinafter referred to as the “City Sewer System”.

The State proposes to decommission its existing sewer collection system and wastewater treatment ponds in Myre-Big-Island State Park and construct a new sewer collection system connected to the City of Albert Lea’s sewer system for transport, treatment, and proper disposal. Said new sewer collection system is hereinafter referred to as the “Park Sewer System”, as shown in the Map and referenced as **Exhibit A**.

The State and the City have determined that connecting the proposed Park Sewer System to the City Sewer System is of mutual and public benefit.

The State has completed the Final Plans for the Park Sewer System which have been approved by the City and are referenced as **Exhibit B**.

The City is prepared to permit the State to connect the Park Sewer System to the City Sewer System at the manhole at the intersection of County State Aid Highway 46 and County State Aid Highway 38, as identified in the Plans referenced as **Exhibit B**.

Upon completion, the administration, operations and maintenance of the Park Sewer System shall be the sole responsibility of the State.

A copy of the City Council resolution authorizing the City to enter into this agreement has been provided as shown in **Exhibit C**.

## **Agreement**

### **1. Term of Agreement**

- 1.1 Effective Date: July 1, 2026, or the date the State obtains all required signatures under Minn. Stat. § 16C.05, subd. 2, whichever is later.
- 1.2 Expiration Date: June 30, 2061, or until all obligations have been satisfactorily fulfilled, whichever occurs first. This agreement shall renew at the end of the term for an additional five (5) year period unless a party gives three (3) months' written notice to the other party to terminate the agreement. This agreement shall continue to automatically renew at the end of each five (5) year period unless the required notice is given.

### **2. Agreement between the Parties**

#### **2.1 State's Duties and Responsibilities. The State shall:**

- a. Solely own and be responsible for the cost of design, construction, operation and maintenance of the Park Sewer System, including all pipe, valves, air release valves, structures, odor control system, sampling manhole, and other necessary components.
- b. Bid and administer all construction contracts for this project, as well as provide all construction engineering, staking, materials testing, record keeping and construction inspection.
- c. Comply with all applicable state and federal environmental laws and regulations, and will obtain any and all necessary environmental reviews, licenses or clearances under any federal or state law or regulation in connection with the construction and operation of the Park Sewer System.
- d. Comply with all applicable requirements of Chapter 44, Article III of the City Municipal Code as published.
- e. Permit the City to review and comment on any major alterations to the Park Sewer System proposed by the State during the term of this Agreement.
- f. Use the Park Sewer System solely for the benefit of the park and its visitors, no other connections to or use of the Park Sewer System will be allowed without the prior written approval of the City.
- g. The total maximum allowable flow from the Park System to the City System shall be:

Peak Day: 10,500 gallons per day

Peak Hour: 180 gallons per minute

- h. Pay the monthly base service charge and consumption fee as set forth in Article 2.1 for as long as the Park System discharges to the City System.
- i. Pay the City the standard sewer access fee, at the time of connection, as set forth in Article 2.1.
- j. Be solely responsible for removal of its infrastructure and restoration of the affected City property to the satisfaction of the City Engineer, and at no cost to the City, upon termination or cancellation of this agreement.

## **2.2 City's Duties and Responsibilities. The City shall:**

- a. Permit the State to discharge sewage flow, subject to the restrictions contained herein, at the connection point with the City Sewer System, as shown on **Exhibit A**. The City will be responsible for treating the wastewater flow from the Park Sewer System at the City Wastewater Treatment Facility.
- b. Be permitted to review and approve any major alterations to the Park Sewer System proposed by the State during the term of this Agreement.
- c. Comply with all applicable local, state and federal environmental laws and regulations, and will obtain any and all necessary environmental reviews, licenses or clearances under any federal or state law or regulation in connection with the transport, treatment, and disposal of sewage from the Park Sewer System beginning at the point of connection to the City Sewer System.
- d. Charge the State a monthly Base Service Charge and Consumption Fee as established in the City's published Fee Schedule for Sanitary Sewer Billing Rates. Future adjustments in the monthly Base Service Charge and Consumption Fee shall be identical with those adjustments for other comparable customers in the City. A metering system installed at the Park Sewer System will be used for calculating monthly volumes to be billed by the City. The Base Service Charge will be for a 2" meter.
- e. Charge the State the same standard sewer access fee as other residential customers in the City as established in the City's published Fee Schedule at the time of connection. Each connection point shown on **Exhibit A** will be assessed a sewer access fee.

## **3. Funding**

The State shall provide funding for its responsibilities under Article 2.1 above through the standard internal purchasing process including, but not limited to, a separate requisition in which funds will be encumbered. The total obligation of the State is also limited to the amount of funds legislatively appropriated and administratively allocated to this Project.

## **4. Authorized Representatives**

The State's Authorized Representative is Carter Vogel, Myre-Big Island State Park Manager, Minnesota Department of Natural Resources, 19499 780<sup>th</sup> Avenue, Albert Lea, MN 56007, 507-668-7061, [carter.vogel@state.mn.us](mailto:carter.vogel@state.mn.us) or their successor.

The City's Authorized Representative is Steven, Jahnke, Albert Lea Public Works Director, City of Albert Lea, 221 East Clark Street, Albert Lea, MN 56007, 507-377-4325, [sjahnke@ci.albertlea.mn.us](mailto:sjahnke@ci.albertlea.mn.us) or their successor.

## **5. Assignment, Amendments, Waiver, and Contract Complete.**

5.1 Assignment. The City may neither assign nor transfer any rights or obligations under this Agreement without the prior consent of the State and a fully executed assignment agreement, executed and approved by the authorized parties or their successors.

5.2 Amendments. Any amendment to this Agreement must be in writing and will not be effective until it has been executed and approved by the authorized parties or their successors.

5.3 Waiver. If the State fails to enforce any provision of this Agreement, that failure does not waive the provision or its right to enforce it.

5.4 Contract Complete. This Agreement contains all negotiations and agreements between the State and the City. No other understanding regarding this Agreement, whether written or oral, may be used to bind either party.

## **6. Liability**

Each party agrees that it will be responsible for its own acts and the results thereof to the extent authorized by law and shall not be responsible for the acts of the other party and the results thereof. The State's liability shall be governed by the provisions of the Minnesota Tort Claims Act, Minnesota Statutes Section 3.736, and other applicable law. The City's liability shall be governed by Minnesota Statutes Sections 466.01 - 466.15, and other applicable law.

## **7. State Audits.**

Under Minn. Stat. § 16C.05, subd. 5, the City's books, records, documents, and accounting procedures and practices relevant to this Agreement are subject to examination by the State, the State Auditor, or Legislative Auditor, as appropriate, for a minimum of six years from the expiration or termination of this Agreement.

## **8. Government Data Practices.**

The City and State must comply with the Minnesota Government Data Practices Act, Minn. Stat. Ch. 13, (or, if the State contracting party is part of the Judicial Branch, with the Rules of Public Access to Records of the Judicial Branch promulgated by the Minnesota Supreme Court as the same may be amended from time to time) as it applies to all data provided by the State under this Agreement, and as it applies to all data created, collected, received, stored, used, maintained, or disseminated by the City under this Contract. The civil remedies of Minn. Stat. § 13.08 apply to the release of the data governed by the Minnesota Government Practices Act, Minn. Stat. Ch. 13, by either the City or the State.

If the City receives a request to release the data referred to in this clause, the City must immediately notify and consult with the State's Authorized Representative as to how the City should respond to the request. The City's response to the request shall comply with applicable law.

## **9. Publicity and Endorsement.**

**9.1 Publicity.** Any publicity regarding the subject matter of this Contract must identify the State as the sponsoring agency and must not be released without prior written approval from the State's Authorized Representative. For purposes of this provision, publicity includes notices, informational pamphlets, press releases, information posted on corporate or other websites, research, reports, signs, and similar public notices prepared by or for the City individually or jointly with others, or any subcontractors, with respect to the program, publications, or services provided resulting from this Contract.

All publicity shall be provided in an accessible format per Minnesota Statute 16E.03, sub. 9. State of Minnesota guidelines for creating accessible electronic documents can be found at the following URL: <https://mn.gov/mnit/programs/accessibility/>.

**9.2 Endorsement.** The City must not claim that the State endorses its products or services.

## **10. Venue**

Venue for all legal proceedings out of this Agreement, or its breach, must be in the appropriate state or federal court with competent jurisdiction in Ramsey County, Minnesota.

## **11. Termination**

**11.1 Termination.** This Agreement may be cancelled by the State at any time, with or without cause, or as necessary as provided in Article 3, upon thirty (30) days written notice to the City. This Agreement may also be cancelled by the City under the conditions set forth by Article 1.2 above or at any time with cause upon thirty (30) days written notice to the State.

**11.2 Termination for Insufficient Funding.** The State may immediately terminate this Agreement if it does not obtain funding from the Minnesota Legislature, or other funding source; or if funding cannot be continued at a level sufficient to allow for the payment of the services covered here. Termination must be by written or fax notice to the City. The State is not obligated to pay for any services that are provided after notice and effective date of termination. However, the City will be entitled to payment, determined on a pro rata basis, for services satisfactorily performed to the extent that funds are available. The State will not be assessed any penalty if the agreement is terminated because of the decision of the Minnesota Legislature, or other funding source, not to appropriate funds. The State must provide the City notice of the lack of funding within a reasonable time of the State's receiving that notice.

## 12. Force Majeure

Neither party shall be responsible to the other or considered in default of its obligations within this Agreement to the extent that performance of any such obligations is prevented or delayed by acts of God, war, riot, disruption of government, or other catastrophes beyond the reasonable control of the party unless the act or occurrence could have been reasonably foreseen and reasonable action could have been taken to prevent the delay or failure to perform. A party relying on this provision to excuse performance must provide the other party prompt written notice of inability to perform and take all necessary steps to bring about performance as soon as practicable.

## 13. E-Verify Certification (in accordance with Minn. Stat. § 16C.075).

For services valued in excess of \$50,000, the City certifies that as of the date of services performed on behalf of the State, City and all its subcontractors will have implemented or be in the process of implementing the federal E-Verify Program for all newly hired employees in the United States who will perform work on behalf of the State. The City is responsible for collecting all subcontractor certifications and may do so utilizing the E-Verify Subcontractor Certification Form available at <http://www.mmd.admin.state.mn.us/doc/EVerifySubCertForm.doc>. All subcontractor certifications must be kept on file with Contractor and made available to the State upon request.

14. Exhibits. The following Exhibits are attached and incorporated into this Contract. In the event of a conflict between the terms of this Contract and its Exhibits, or between Exhibits, the order of precedence is first the Contract, and then in the following order:

**Exhibit A: Map of State Park Ownership and Park Sewer System Layout**

**Exhibit B: Final Plans for the Myre Sewer Improvements** (includes CSAH 38 right-of-way)

**Exhibit C: City Council Meeting Minutes/Resolution** (supporting this agreement)

[The Balance OF This Page is Left Intentionally Blank]

**1. State Encumbrance Verification**

*Individual certifies that funds have been encumbered as required by Minn. Stat. §§ 16A.15 and 16C.05*

Print Name: \_\_\_\_\_

Signature: \_\_\_\_\_

Title: \_\_\_\_\_ Date: \_\_\_\_\_

SWIFT Contract No. \_\_\_\_\_

**2. City of Albert Lea**

Print Name: \_\_\_\_\_

Signature: \_\_\_\_\_

Title: \_\_\_\_\_ Date: \_\_\_\_\_

**City of Albert Lea**

Print Name: \_\_\_\_\_

Signature: \_\_\_\_\_

Title: \_\_\_\_\_ Date: \_\_\_\_\_

**3. State Agency**

*With delegated authority*

Print Name: \_\_\_\_\_

Signature: \_\_\_\_\_

Title: \_\_\_\_\_ Date: \_\_\_\_\_

**4. Commissioner of Administration**

*As delegated to The Office of State Procurement*

Print Name: \_\_\_\_\_

Signature: \_\_\_\_\_

Title: \_\_\_\_\_ Date: \_\_\_\_\_

Admin ID: \_\_\_\_\_

# Exhibit A

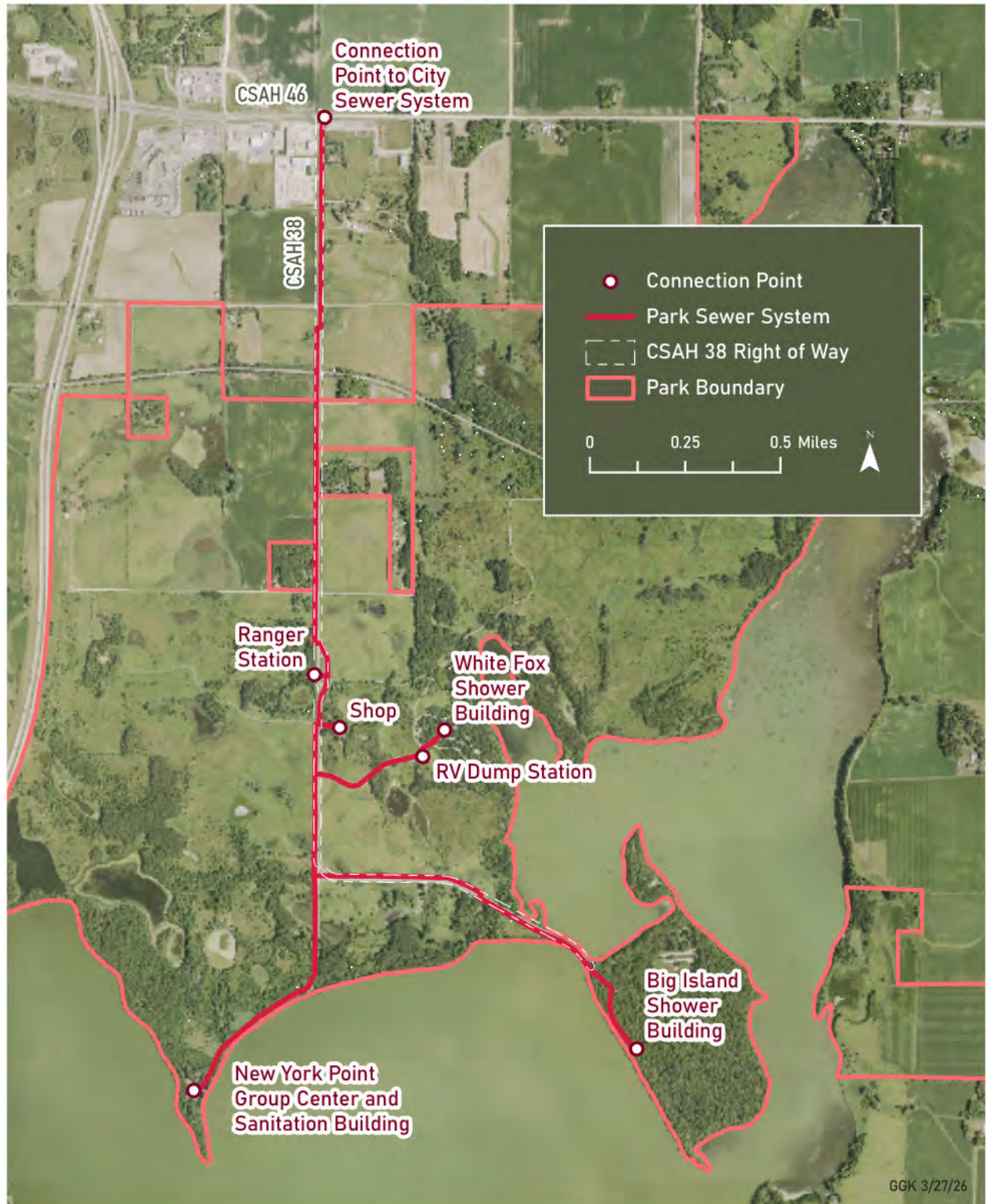

RESOLUTION 26-

Introduced by Councilor

RESOLUTION DETERMINING THE REVENUES RAISED BY THE CITY'S 0.5%  
SALES AND USE TAX WILL MEET OR EXCEED THE AUTHORIZED AMOUNT  
ON OR BEFORE SEPTEMBER 30, 2026, AND THE TAX SHALL EXPIRE ON  
THAT DATE

WHEREAS, pursuant to 2005 Minn. Laws 1st Spec. Sess. ch. 3, art. 5, § 39, as subsequently amended (the "Amended Special Law"), and authority granted by voters at a special election held on November 8, 2005, the City of Albert Lea, Minnesota, previously adopted Ordinance No. 100, 3d, § 6, 2-13-2006 imposing a sales and use tax of 0.50% (the "Watershed Sales Tax") to finance lake improvement projects detailed in the Shell Rock River Watershed Plan (the "Watershed Projects"); and

WHEREAS, the Watershed Projects have resulted in benefits to both the residents and businesses of the City of Albert Lea and to non-resident visitors and businesses; and

WHEREAS, by its terms, and pursuant to Ordinance No. 208, 6d, § 5, 8-28-2017 adopted by the City of Albert Lea, the taxes imposed under the Amended Special Law expire at the earlier of (1) 30 years after the taxes are first imposed or (2) when the City Council first determines that the amount of revenues raised to pay for the Watershed Projects shall meet or exceed the sum of \$30,000,000 (the "Authorized Amount"); and

WHEREAS, based on historical receipts, the City of Albert Lea projects that the proceeds generated by the Watershed Sales Tax for Watershed Projects will meet or exceed the Authorized Amount in July or August of 2026;

NOW, THEREFORE, BE IT RESOLVED AS FOLLOWS BY THE CITY COUNCIL OF ALBERT LEA, MINNESOTA:

1. The City Council hereby determines that the revenues raised by the Watershed Sales Tax for the Watershed Projects will meet or exceed the Authorized Amount on or before September 30, 2026 (the "Termination Date").
2. Pursuant to the terms of the Amended Special Law and Minnesota Statutes, Section 297A, the Watershed Sales Tax will thereby expire and be decertified on the Termination Date.
3. Upon expiration of the Watershed Sales Tax on the Termination Date, Sections 40.057 through 40.069 of the Albert Lea, Minnesota Code of Ordinances shall be repealed.
4. The City Manager and Finance Director are directed to cause a copy of this resolution and a decertification letter to be submitted to the appropriate officials at the Minnesota Department of Revenue no later than 90 days prior to the Termination Date.

5. All actions taken by the City Manager and Finance Director in connection with the Watershed Sales Tax and its termination are hereby ratified, confirmed, and approved, and the City Manager and the Finance Director are hereby authorized to take any and all actions reasonably necessary to implement the terms of this Resolution.
6. This Resolution shall take effect from and after its adoption.

That the motion for the adoption of the foregoing resolution was duly seconded by Councilor , and upon a vote being taken thereon, the following voted in favor thereof: Councilors Christensen, Baker, Herman, Olson, Van Beek, Anderson, and Mayor Murray;

And the following voted against the same: None. Mayor Murray declared the resolution passed.

Introduced and passed this 8<sup>th</sup> day of June, 2026

---

Mayor Rich Murray

Filed and attested this 9<sup>th</sup> day of June, 2026

---

Secretary of the Council

STATE OF MINNESOTA

FREEBORN COUNTY  
CITY OF ALBERT LEA

I, the undersigned, being the duly qualified and acting City Clerk of the City of Albert Lea, Minnesota, DO HEREBY CERTIFY that I have compared the attached and foregoing extract of minutes with the original thereof on file in my office, and that the same is a full, true and complete transcript of the minutes of a meeting of the City Council, duly called and held on the date therein indicated, insofar as the minutes relate to determining that the revenues raised by the City's 0.5% sales and use tax will meet or exceed the authorized amount on or before September 30, 2026, and the tax shall expire on that date.

WITNESS my hand on June 8, 2026.

---

City Clerk

RESOLUTION 26-

Introduced by Councilor

RESOLUTION PROVIDING FOR THE ISSUANCE AND SALE OF \$5,310,000  
GENERAL OBLIGATION BONDS, SERIES 2026A

A. WHEREAS, the City Council (the "Council") of the City of Albert Lea, Minnesota (the "City") has heretofore determined that it is necessary and expedient to issue the City's \$5,310,000 General Obligation Bonds, Series 2026A (the "Bonds"), to finance the City's annual street and water projects; and

B. WHEREAS, the City has retained Ehlers & Associates, Inc., in Minneapolis, Minnesota ("Ehlers"), as its independent municipal advisor for the Bonds in accordance with Minnesota Statutes, Section 475.60, Subdivision 2(9).

NOW, THEREFORE, BE IT RESOLVED BY THE CITY COUNCIL OF ALBERT LEA, MINNESOTA:

1. Authorization. The Council hereby authorizes Ehlers to assist the City for the sale of the Bonds.

2. Meeting; Proposal Opening. The Council shall meet at 7:00 P.M. on July 13, 2026, for the purpose of considering proposals for and awarding the sale of the Bonds.

3. Official Statement. In connection with said sale, the officers or employees of the City are hereby authorized to cooperate with Ehlers and participate in the preparation of an official statement for the Bonds and to execute and deliver it on behalf of the City upon its completion.

That the motion for the adoption of the foregoing resolution was duly seconded by Councilor , and upon a vote being taken thereon, the following voted in favor thereof: Councilors Christensen, Baker, Herman, Van Beek, Olson, Anderson, and Mayor Murray; and, the following voted against the same: None.

Introduced and passed this 8<sup>th</sup> day of June, 2026

---

Mayor Murray

Filed and attested this 9<sup>th</sup> day of June, 2026

---

Secretary of the Council

STATE OF MINNESOTA  
FREEBORN COUNTY  
CITY OF ALBERT LEA

I, the undersigned, being the duly qualified and acting City Clerk of the City of Albert Lea, Minnesota, DO HEREBY CERTIFY that I have compared the attached and foregoing extract of minutes with the original thereof on file in my office, and that the same is a full, true and complete transcript of the minutes of a meeting of the City Council, duly called and held on the date therein indicated, insofar as the minutes relate to providing for the issuance and sale of \$5,310,000 General Obligation Bonds, Series 2026A.

WITNESS my hand on June 8, 2026.

---

Daphney Maras, City Clerk

RESOLUTION 26-

Introduced by Councilor

RESOLUTION DESIGNATING "2-HOUR" PARKING ON THE SOUTH SIDE OF COLLEGE STREET FROM S. BROADWAY AVENUE (TH-65) TO NEWTON AVENUE AND AUTHORIZING AN INTERSECTION STUDY OF E. COLLEGE STREET & NEWTON AVENUE

WHEREAS, the City of Albert Lea has received a request from Freeborn County to designate the on-street parking on the south side of College Street from S. Broadway Avenue (TH 65) to Newton Avenue as 2-hour parking between the hours of 8:00 a.m. and 5:00 p.m.; and

WHEREAS, pedestrian safety concerns including speeding and failure to yield to pedestrians have been noted at the intersection of E. College Street and Newton Avenue.

NOW THEREFORE, BE IT RESOLVED BY THE CITY COUNCIL OF ALBERT LEA, MINNESOTA:

Sec. 1. That the on-street parking along the south side of College Street from S. Broadway Avenue (TH 65) to Newton Avenue shall be designated as 2-Hour parking between the hours of 8:00 am to 5:00 pm.

Sec. 2. That the City Engineer is hereby authorized and directed to retain a consultant to conduct a study of the intersection of E. College Street and Newton Avenue to include, but not be limited to pedestrian crossing improvements including a Rectangular Rapid Flashing Beacon (RRFB), curb bumpouts, and enhanced markings and/or signage.

That the motion for the adoption of the foregoing resolution was duly seconded by Councilor , and upon a vote being taken thereon, the following voted in favor thereof: Councilors Christensen, Baker, Herman, Olson, Van Beek, Anderson and Mayor Murray;

And the following voted against the same: None. Mayor Murray declared the resolution passed.

Introduced and passed this 8<sup>th</sup> day of June, 2026

---

Mayor Rich Murray

Filed and attested this 9<sup>th</sup> day of June, 2026

---

Secretary of the Council

RESOLUTION 26-

Introduced by Councilor

RESOLUTION ACCEPTING DONATIONS AS PRESENTED  
TO THE CITY OF ALBERT LEA

WHEREAS, The City of Albert Lea is generally authorized to accept donations pursuant to Minnesota Statutes Section 465.03 for the benefit of its citizens.

WHEREAS, individual persons and/or entities have offered to contribute donation(s) as set forth below to the city:

<b><u>Donation/Donors</u></b>	<b><u>Amount or Item</u></b>
Friends of the Albert Lea Public Library	\$1,443.08 to the Albert Lea Public Library

WHEREAS, the City Council finds that it is appropriate to accept the donation offered.

NOW, THEREFORE, BE IT RESOLVED BY THE CITY COUNCIL OF ALBERT LEA, MINNESOTA:

Sec. 1. That the donation described is accepted and

Sec. 2. The City of Albert Lea is hereby directed to issue receipts to the donor acknowledging the City's receipt of the donation.

That the motion for the adoption of the foregoing resolution was duly seconded by Councilor , and upon a vote being taken thereon, the following voted in favor thereof: Councilors Christensen, Baker, Herman, Van Beek, Olson, Anderson, and Mayor Murray; and, the following voted against the same: None.

Introduced and passed this 8<sup>th</sup> day of June, 2026

---

Mayor Murray

Filed and attested this 9<sup>th</sup> day of June, 2026

---

Secretary of the Council

Friends of the Albert Lea Public Library Donations  
January through May 2026

<b>Month</b>	<b>Purpose/Use of Funds</b>	<b>Amount</b>
January	Adult Winter Reading Program	\$290.44
January	Early Literacy Programs	\$316.00
January-May	Tween and Teen Programs	\$293.64
February	Programs for Elementary School Aged Children	\$308.86
March	Special Events	\$234.14

Total: \$1,443.08

RESOLUTION 26-

Introduced by Councilor

RESOLUTION ACKNOWLEDGING THE ESTABLISHMENT OF THE ALBERT LEA  
PORT AUTHORITY LEVY

WHEREAS, The City of Albert Lea (City) and the Albert Lea Port Authority (Port Authority) share the same legal boundaries; and

WHEREAS, the Port Authority has the legal authority under MN Statute 469.053 to establish its own levy within the City; and

WHEREAS, the Port Authority has not established a levy and has notified the Freeborn County Auditor as required pursuant to MN Statutes 275.067, and

WHEREAS, the City of Albert Lea recognized there may be necessary investment in infrastructure and land to expand the existing industrial park that has seen significant sales and growth in the last 5 years; and

WHEREAS, the City Council finds that it is appropriate for the Port Authority to establish a levy and work in conjunction with the City on economic development matters.

NOW, THEREFORE, BE IT RESOLVED BY THE CITY COUNCIL OF ALBERT LEA, MINNESOTA:

Sec. 1. The City recognizes and finds no reason to object to the establishment of a levy for the Port Authority per state statute 469.053.

That the motion for the adoption of the foregoing resolution was duly seconded by Councilor , and upon a vote being taken thereon, the following voted in favor thereof: Councilors Christensen, Baker, Herman, Van Beek, Olson, Anderson, and Mayor Murray; and, the following voted against the same: None.

Introduced and passed this 8<sup>th</sup> day of June, 2026

---

Mayor Murray

Filed and attested this 9<sup>th</sup> day of June, 2026

---

Secretary of the Council

RESOLUTION 26-

Introduced by Councilor

RESOLUTION APPROVING AMENDMENTS TO THE ALBERT LEA PORT  
AUTHORITY BY-LAWS

WHEREAS, The Albert Lea Port Authority (Port Authority) has to amend by-laws of its organization and the City Council has to approve those changes.

NOW, THEREFORE, BE IT RESOLVED BY THE CITY COUNCIL OF ALBERT LEA, MINNESOTA:

Sec. 1. The City approve the changes to Article 2 of the Port Authority By-Laws:

**ARTICLE II. Governing body.**

- A. The powers of the port authority shall be vested in the commissioners of the port authority in office at any time, a majority of whom shall constitute a quorum for all purposes. Such commissioners shall be seven (7) in number. Effective January 1, 2004, new commissioners shall be appointed to the port authority board by the city council.
- B. The initial terms shall be as follows: one (1) member each for a term of one (1), two (2), three (3), four (4) and five (5) years, respectively, and two (2) members for terms of six (6) years. For subsequent terms, the term is six (6) years.
- C. A vacancy on the port authority board must be filled by the appointing authority for the balance of the vacant term, subject to the same appointment and consent required for an appointment for a full term.
- D. The term of a member of the city council appointed to the board shall be co-terminus with the appointee's city council term.
- E. Board members may live outside the city limits if:
  - (1) They are able to show a vested interest in the community by virtue of owning property, a business, or working full time in Freeborn County.
  - (2) Have experience, training and education applicable to the Albert Lea Port Authority.

That the motion for the adoption of the foregoing resolution was duly seconded by Councilor , and upon a vote being taken thereon, the following voted in favor thereof: Councilors

Christensen, Baker, Herman, Van Beek, Olson, Anderson, and Mayor Murray; and, the following voted against the same: None.

Introduced and passed this 8<sup>th</sup> day of June, 2026

---

Mayor Murray

Filed and attested this 9<sup>th</sup> day of June, 2026

---

Secretary of the Council

RESOLUTION 26-

Introduced by Councilor

RESOLUTION APPROVING INCREASE IN BUILDING MAINTENANCE STAFF  
HOURS OF EMPLOYMENT

WHEREAS, in order to meet the maintenance needs of city buildings and to authorize a post budget change to staffing, the City Council shall pass a resolution approving the change; and

WHEREAS, once approved by the City Council, the City Manager is authorized to change the hour allotment and employment status of the building maintenance employee starting at the next payroll cycle.

NOW, THEREFORE, BE IT RESOLVED BY THE CITY COUNCIL OF ALBERT LEA, MINNESOTA:

Sec. 1. The City Manager is authorized to increase the hours of employment to 40 hours weekly for one building maintenance employee at Grade 2.

That the motion for the adoption of the foregoing resolution was duly seconded by Councilor , and upon a vote being taken thereon, the following voted in favor thereof: Councilors Christensen, Baker, Herman, Van Beek, Olson, Anderson, and Mayor Murray; and, the following voted against the same: None.

Introduced and passed this 8<sup>th</sup> day of June, 2026

---

Mayor Murray

Filed and attested this 9<sup>th</sup> day of June, 2026

---

Secretary of the Council

RESOLUTION 26

Introduced by Councilor

RESOLUTION APPROVING CLAIMS

NOW, THEREFORE, BE IT RESOLVED BY THE CITY COUNCIL OF ALBERT LEA, MINNESOTA:

Sec. 1. That the claims, as presented in the attached exhibit in the amount of \$1,283,031.83 are approved and the City Treasurer is hereby directed to disburse said amounts with payment to be made from the fund indicated.

That the motion for the adoption of the foregoing resolution was duly seconded by Councilor , and upon a vote being taken thereon, the following voted in favor thereof: Councilors Christensen, Baker, Herman, Olson, Van Beek, Anderson and Mayor Murray;

And the following voted against the same: None. Mayor Murray declared the resolution passed.

Introduced and passed this 8<sup>th</sup> day of June, 2026

---

Mayor Rich Murray

Filed and attested this 9<sup>th</sup> day of June, 2026

---

Secretary of the Council

## Claims Over \$25,000

### City of Albert Lea Council Meeting 06/08/2026

- **\$25,986.00 – MES Acquisition Inc**  
Bunker Gear Sets (6)
- **\$26,302.13 – Jensen Excavating & Trucking**  
Pay Estimate 1 – St. Mary & 14<sup>th</sup> Street Reconstruction
- **\$29,299.50 – Freeborn County Co-op Oil**  
Unleaded Fuel
- **\$36,329.33 – H & M Underground Solutions**  
Pay Estimate 7 – Lead Service Line Replacement Project
- **\$58,407.23 – Brennan Construction of Minnesota Inc**  
Arena Lobby Expansion
- **\$62,727.50 – GFY Custom Crafts LLC**  
409 Clark St W – Labor & Expenses
- **\$63,255.50 – GFY Customer Crafts LLC**  
915 Autumn St – Labor & Expenses



## Claims Over \$25,000

### City of Albert Lea Council Meeting 06/08/2026

- **\$71,457.00 – Solar Connection Inc**  
Solar on Public Building – City Hall
- **\$97,645.80 – BCM Construction**  
Pay Estimate 12 – Lead Service Line Replacement Project
- **\$226,825.04 – Southeast Service Coop**  
Health Insurance – Approximately 87% Employer and 13% Employee

# Accounts Payable

## Checks for Approval

User: nthoms  
 Printed: 6/4/2026 - 1:08 PM



Check Number	Check Date	Fund	Account Name	Vendor Name	Void	Amount
0	05/29/2026	101 General	State Withholding Payable	Minnesota Department of Revenue		20,808.86
0	05/29/2026	101 General	Deferred Compensation Payable	MN State Retirement - Empower		50.00
0	05/29/2026	101 General	Other Payroll Deduct Payable	Minnesota Department of Human Services		1,276.39
0	05/29/2026	101 General	Deferred Compensation Payable	MN State Retirement - Empower		1,266.89
0	05/29/2026	101 General	Accrued Medicare Payable	Internal Revenue Service		130.48
0	05/29/2026	101 General	Accrued PERA Payable	PERA		55,158.32
0	05/29/2026	101 General	Federal Withholding Payable	Internal Revenue Service		43,233.74
0	05/29/2026	101 General	Deferred Compensation Payable	Mission Square Plan Services		2,814.00
0	05/29/2026	101 General	Deferred Compensation Payable	Mission Square Plan Services		4,497.06
0	05/29/2026	101 General	Accrued PERA Payable	PERA		40,921.71
0	05/29/2026	101 General	Other Payroll Deduct Payable	WEX Health Inc		12,116.96
0	05/29/2026	101 General	Deferred Compensation Payable	Mission Square Plan Services		1,035.46
0	05/29/2026	101 General	Accrued Medicare Payable	Internal Revenue Service		6,881.26
0	05/29/2026	101 General	Accrued FICA Payable	Internal Revenue Service		17,546.13
0	05/29/2026	101 General	Accrued Medicare Payable	Internal Revenue Service		6,881.26
0	05/29/2026	101 General	Accrued Medicare Payable	Internal Revenue Service		130.48
0	05/29/2026	101 General	Deferred Compensation Payable	Mission Square Plan Services		964.96
0	05/29/2026	101 General	Federal Withholding Payable	Internal Revenue Service		1,773.82
0	05/29/2026	101 General	State Withholding Payable	Minnesota Department of Revenue		649.55
0	05/29/2026	101 General	Accrued FICA Payable	Internal Revenue Service		17,546.13
0	05/29/2026	101 General	Other Payroll Deduct Payable	AFLAC Group Insurance		389.88
0	05/29/2026	101 General	Dental Insurance Payable	MetLife		1,940.97
0	05/29/2026	101 General	Deferred Compensation Payable	Nationwide Retirement Solutions		103.20
0	05/29/2026	101 General	Life Insurance Payable	Sun Life Financial		1.72
0	05/29/2026	101 General	Life Insurance Payable	Sun Life Financial		1.72
0	05/29/2026	101 General	Other Payroll Deduct Payable	AFLAC Group Insurance		570.80
0	05/29/2026	101 General	Vision Care Payable	Fidelity Security Life		8.08
0	05/29/2026	101 General	Other Payroll Deduct Payable	AFLAC Group Insurance		549.98
0	05/29/2026	101 General	Vision Care Payable	Fidelity Security Life		380.53
0	05/29/2026	101 General	Other Payroll Deduct Payable	AFLAC Group Insurance		398.30
0	05/29/2026	101 General	Long-term Disability Payable	Sun Life Financial		1,232.92
0	05/29/2026	101 General	Life Insurance Payable	Sun Life Financial		247.68
0	05/29/2026	101 General	Dental Insurance Payable	MetLife		33.17
0	05/29/2026	101 General	Vision Care Payable	Fidelity Security Life		374.47

Check Number	Check Date	Fund	Account Name	Vendor Name	Void	Amount
0	05/29/2026	101 General	Deferred Compensation Payable	Nationwide Retirement Solutions		85.35
0	05/29/2026	101 General	Other Payroll Deduct Payable	Sun Life Financial		1,630.48
0	05/29/2026	101 General	Dental Insurance Payable	MetLife		1,916.08
0	05/29/2026	101 General	Life Insurance Payable	Sun Life Financial		1.72
0	05/29/2026	101 General	Deferred Compensation Payable	Nationwide Retirement Solutions		359.28
0	05/29/2026	101 General	Deferred Compensation Payable	Nationwide Retirement Solutions		1,843.53
0	05/29/2026	101 General	Other Payroll Deduct Payable	Sun Life Financial		1,620.98
0	05/31/2026	602 Sewer	Supplies	US Bank		569.99
0	05/31/2026	101 General	Supplies	US Bank		158.36
0	05/31/2026	101 General	Travel Expense	US Bank		372.90
0	05/31/2026	225 Airport	Vehicle/Equipment Parts	US Bank		1,039.92
0	05/31/2026	101 General	Training/ Instruction Supplies	US Bank		321.00
0	05/31/2026	101 General	Training & Education	US Bank		625.00
0	05/31/2026	101 General	Training & Education	US Bank		50.00
0	05/31/2026	101 General	Supplies	US Bank		11.22
0	05/31/2026	702 Computer Equip Capital Purchas	Minor Computer Equip	US Bank		1,235.04
0	05/31/2026	101 General	Software/Software Subscription	US Bank		779.88
0	05/31/2026	101 General	Furniture, Equipment & Tools	US Bank		109.99
0	05/31/2026	702 Computer Equip Capital Purchas	Minor Computer Equip	US Bank		1,235.04
0	05/31/2026	601 Water	Postage	US Bank		11.50
0	05/31/2026	101 General	Safety Equipment	US Bank		68.34
0	05/31/2026	496 2026 Projects	Cash and Investments	US Bank		-8.60
0	05/31/2026	601 Water	Credit Card & Bank Fees	US Bank		20.01
0	05/31/2026	603 Solid Waste	Supplies	US Bank		9.98
0	05/31/2026	101 General	Software/Software Subscription	US Bank		8.88
0	05/31/2026	101 General	Postage	US Bank		10.66
0	05/31/2026	702 Computer Equip Capital Purchas	Minor Computer Equip	US Bank		1,235.04
0	05/31/2026	602 Sewer	Supplies	US Bank		237.98
0	05/31/2026	101 General	Motor Fuels	US Bank		160.59
0	05/31/2026	701 CG - Vehicle & Equip Capital	Vehicles (Licensed)	US Bank		69.95
0	05/31/2026	101 General	Travel Expense	US Bank		129.45
0	05/31/2026	101 General	Software/Software Subscription	US Bank		60.00
0	05/31/2026	101 General	Travel Expense	US Bank		255.20
0	05/31/2026	101 General	Travel Expense	US Bank		66.00
0	05/31/2026	101 General	Supplies	US Bank		18.33
0	05/31/2026	101 General	Credit Card & Bank Fees	US Bank		0.72
0	05/31/2026	602 Sewer	Credit Card & Bank Fees	US Bank		102.61
0	05/31/2026	496 2026 Projects	Taxes, License & Permit Fees	US Bank		400.00
0	05/31/2026	101 General	Travel Expense	US Bank		358.38
0	05/31/2026	101 General	Supplies	US Bank		17.25
0	05/31/2026	101 General	Dues,Subscriptions,Ee Licenses	US Bank		6.47
0	05/31/2026	702 Computer Equip Capital Purchas	Minor Computer Equip	US Bank		1,235.04
0	05/31/2026	101 General	Supplies	US Bank		71.02
0	05/31/2026	496 2026 Projects	Cash and Investments	US Bank		-400.00

Check Number	Check Date	Fund	Account Name	Vendor Name	Void	Amount
0	05/31/2026	101 General	Motor Fuels	US Bank		211.97
0	05/31/2026	101 General	Credit Card & Bank Fees	US Bank		38.80
0	05/31/2026	496 2026 Projects	Cash and Investments	US Bank		8.60
0	05/31/2026	101 General	Training & Education	US Bank		122.50
0	05/31/2026	101 General	Supplies	US Bank		378.00
0	05/31/2026	101 General	Software/Software Subscription	US Bank		256.82
0	05/31/2026	101 General	Supplies	US Bank		38.71
0	05/31/2026	496 2026 Projects	Cash and Investments	US Bank		400.00
0	05/31/2026	101 General	Refuse Disposal	US Bank		245.84
0	05/31/2026	702 Computer Equip Capital Purchas	Minor Computer Equip	US Bank		1,235.04
0	05/31/2026	101 General	Travel Expense	US Bank		129.45
0	05/31/2026	101 General	Software/Software Subscription	US Bank		60.00
0	05/31/2026	702 Computer Equip Capital Purchas	Minor Computer Equip	US Bank		1,235.04
0	05/31/2026	101 General	Motor Fuels	US Bank		224.87
0	05/31/2026	101 General	Training & Education	US Bank		155.70
0	05/31/2026	101 General	Supplies	US Bank		-20.48
0	05/31/2026	101 General	Supplies	US Bank		20.48
0	05/31/2026	101 General	Dues,Subscriptions,Ee Licenses	US Bank		40.00
0	05/31/2026	702 Computer Equip Capital Purchas	Minor Computer Equip	US Bank		1,235.04
0	05/31/2026	101 General	Travel Expense	US Bank		303.20
0	05/31/2026	101 General	Travel Expense	US Bank		129.45
0	05/31/2026	601 Water	Taxes, License & Permit Fees	US Bank		400.00
0	05/31/2026	496 2026 Projects	Taxes, License & Permit Fees	US Bank		8.60
0	05/31/2026	602 Sewer	Furniture, Equipment & Tools	US Bank		167.98
0	05/31/2026	101 General	Medical Flex Payable	WEX Health Inc		176.72
0	05/31/2026	101 General	Training & Education	US Bank		155.70
0	05/31/2026	101 General	Supplies	US Bank		106.04
0	05/31/2026	702 Computer Equip Capital Purchas	Minor Computer Equip	US Bank		1,235.04
0	05/31/2026	101 General	Travel Expense	US Bank		104.73
0	05/31/2026	101 General	Training & Education	US Bank		50.00
0	05/31/2026	101 General	Supplies	US Bank		687.65
0	05/31/2026	702 Computer Equip Capital Purchas	Minor Computer Equip	US Bank		1,038.51
0	05/31/2026	602 Sewer	Furniture, Equipment & Tools	US Bank		19.99
0	05/31/2026	101 General	Advertising - Other	US Bank		23.51
0	05/31/2026	101 General	Motor Fuels	US Bank		20.00
0	05/31/2026	101 General	Uniforms	US Bank		189.73
0	05/31/2026	101 General	Supplies	US Bank		420.71
0	05/31/2026	101 General	Supplies	US Bank		11.22
0	05/31/2026	101 General	Credit Card & Bank Fees	US Bank		87.62
0	05/31/2026	101 General	Training & Education	US Bank		500.00
0	05/31/2026	101 General	Training & Education	US Bank		50.00
0	05/31/2026	101 General	Direct Primary Care	Kavira Health		27.00
0	05/31/2026	101 General	Supplies	US Bank		29.25
0	05/31/2026	603 Solid Waste	Credit Card & Bank Fees	US Bank		552.11

Check Number	Check Date	Fund	Account Name	Vendor Name	Void	Amount
0	05/31/2026	101 General	Supplies	US Bank		23.00
0	05/31/2026	101 General	Supplies	US Bank		65.23
0	05/31/2026	101 General	Postage	US Bank		8.52
0	05/31/2026	101 General	Training & Education	US Bank		300.00
0	05/31/2026	601 Water	Furniture, Equipment & Tools	US Bank		5.88
0	05/31/2026	101 General	Vehicle/Equipment Parts	US Bank		604.08
0	05/31/2026	602 Sewer	Lubricants & Additives	US Bank		19.98
0	05/31/2026	702 Computer Equip Capital Purchas	Minor Computer Equip	US Bank		1,235.04
0	05/31/2026	101 General	Travel Expense	US Bank		72.00
0	05/31/2026	101 General	Training & Education	US Bank		50.00
0	05/31/2026	702 Computer Equip Capital Purchas	Minor Computer Equip	US Bank		1,235.04
0	05/31/2026	101 General	Credit Card & Bank Fees	US Bank		1,173.86
0	05/31/2026	601 Water	Taxes, License & Permit Fees	US Bank		8.60
0	05/31/2026	101 General	Postage	US Bank		11.60
0	05/31/2026	602 Sewer	Supplies	US Bank		1,071.20
0	06/08/2026	101 General	Health Insurance	Southeast Service Coop		3,969.78
0	06/08/2026	101 General	Medical Insurance Payable	Southeast Service Coop		222,855.26
0	06/08/2026	101 General	Medical Flex Payable	WEX Health Inc		70.52
0	06/08/2026	101 General	Credit Card & Bank Fees	Global Payments, Inc		2,216.45
0	06/08/2026	101 General	Travel Expense	Mitch Mulder		146.45
0	06/08/2026	101 General	Vehicle/Equipment Parts	Fastenal Company		8.93
0	06/08/2026	602 Sewer	Dues,Subscriptions,Ee Licenses	Matthew Wahlers		45.00
0	06/08/2026	101 General	Travel Expense	Sy Vanthavong		53.55
0	06/08/2026	101 General	Expert & Professional Services	First Choice Background Screening		24.50
0	06/08/2026	232 Housing Program Fund	New Home Construction	GFY Custom Crafts LLC		62,727.50
0	06/08/2026	602 Sewer	Travel Expense	Brandon Huston		12.87
0	06/08/2026	602 Sewer	Supplies	Fastenal Company		31.83
0	06/08/2026	101 General	Uniforms	Fastenal Company		263.48
0	06/08/2026	602 Sewer	Expert & Professional Services	Minnesota Valley Testing Laboratories		78.00
0	06/08/2026	101 General	Legal Fees - Contracted	Lakes National Law LLP		7,500.00
0	06/08/2026	101 General	Supplies	Fastenal Company		18.43
0	06/08/2026	602 Sewer	Dues,Subscriptions,Ee Licenses	Canadian Pacific Railway		150.00
0	06/08/2026	602 Sewer	Travel Expense	Brandon Huston		22.42
0	06/08/2026	602 Sewer	Travel Expense	Brandon Huston		451.66
0	06/08/2026	101 General	Building Repair Supplies	Fastenal Company		36.65
0	06/08/2026	101 General	Training & Education	Blair Bonnerup		88.45
0	06/08/2026	602 Sewer	Expert & Professional Services	Minnesota Valley Testing Laboratories		72.00
0	06/08/2026	601 Water	Expert & Professional Services	BCM Construction		97,645.80
0	06/08/2026	101 General	Supplies	Fastenal Company		9.90
0	06/08/2026	232 Housing Program Fund	New Home Construction	GFY Custom Crafts LLC		63,255.50
0	06/08/2026	101 General	Legal Fees - Contracted	Lakes National Law LLP		2,500.00
0	06/08/2026	101 General	Supplies	Kristi Brutlag		21.75
0	06/08/2026	101 General	Vehicle/Equipment Parts	Fastenal Company		17.09
0	06/08/2026	602 Sewer	Expert & Professional Services	Minnesota Valley Testing Laboratories		825.25

Check Number	Check Date	Fund	Account Name	Vendor Name	Void	Amount
0	06/08/2026	232 Housing Program Fund	New Home Construction	GFY Custom Crafts LLC		480.00
0	06/08/2026	601 Water	Supplies	Fastenal Company		18.34
0	06/08/2026	412 Recreation Facilities Project	Building & Bldg Improvements	Brennan Construction of Minnesota Inc		58,407.23
0	06/08/2026	601 Water	Expert & Professional Services	Platinum Plumbing Solutions LLC		21,680.63
0	06/08/2026	601 Water	Supplies	Fastenal Company		293.79
0	06/08/2026	601 Water	Supplies	Fastenal Company		14.82
0	06/08/2026	101 General	Travel Expense	Jeffrey Strom		125.30
0	06/08/2026	101 General	Travel Expense	Sy Vanthavong		184.15
	05/27/2026	101 General	Gas Utilities	Minnesota Energy Resources		50.06
	05/27/2026	101 General	Gas Utilities	Minnesota Energy Resources		153.96
	05/27/2026	101 General	Gas Utilities	Minnesota Energy Resources		18.81
	05/27/2026	101 General	Gas Utilities	Minnesota Energy Resources		62.49
	05/27/2026	101 General	Gas Utilities	Minnesota Energy Resources		20.83
	05/27/2026	230 Economic Development	Gas Utilities	Minnesota Energy Resources		74.21
	05/27/2026	101 General	Gas Utilities	Minnesota Energy Resources		207.48
	05/27/2026	101 General	Gas Utilities	Minnesota Energy Resources		33.78
	05/27/2026	601 Water	Gas Utilities	Minnesota Energy Resources		275.95
	05/27/2026	101 General	Gas Utilities	Minnesota Energy Resources		18.81
	05/27/2026	101 General	Hot Spots	T-Mobile		1,285.77
	06/08/2026	101 General	Lodging Tax Payable	Albert Lea Convention & Visitors Bureau		9,082.80
	06/08/2026	101 General	Building Maintenance	Albert Lea Electric		2,245.88
	06/08/2026	101 General	Vehicle and Equipment Repairs	Albert Lea Electric		294.00
	06/08/2026	412 Recreation Facilities Project	Building & Bldg Improvements	Albert Lea Electric		10,596.00
	06/08/2026	101 General	Dues,Subscriptions,Ee Licenses	Albert Lea Newspapers Inc		132.00
	06/08/2026	496 2026 Projects	Legal Notices & Recording	Albert Lea Newspapers, Inc		125.99
	06/08/2026	101 General	Legal Notices & Recording	Albert Lea Newspapers, Inc		138.89
	06/08/2026	496 2026 Projects	Cash and Investments	Albert Lea Newspapers, Inc		194.36
	06/08/2026	496 2026 Projects	Cash and Investments	Albert Lea Newspapers, Inc		288.96
	06/08/2026	496 2026 Projects	Cash and Investments	Albert Lea Newspapers, Inc		-194.36
	06/08/2026	101 General	Legal Notices & Recording	Albert Lea Newspapers, Inc		95.03
	06/08/2026	496 2026 Projects	Legal Notices & Recording	Albert Lea Newspapers, Inc		210.70
	06/08/2026	496 2026 Projects	Cash and Investments	Albert Lea Newspapers, Inc		-210.70
	06/08/2026	496 2026 Projects	Cash and Investments	Albert Lea Newspapers, Inc		125.99
	06/08/2026	496 2026 Projects	Cash and Investments	Albert Lea Newspapers, Inc		210.70
	06/08/2026	496 2026 Projects	Cash and Investments	Albert Lea Newspapers, Inc		-288.96
	06/08/2026	496 2026 Projects	Legal Notices & Recording	Albert Lea Newspapers, Inc		288.96
	06/08/2026	496 2026 Projects	Cash and Investments	Albert Lea Newspapers, Inc		-125.99
	06/08/2026	496 2026 Projects	Legal Notices & Recording	Albert Lea Newspapers, Inc		194.36
	06/08/2026	101 General	Supplies	Amazon Capital Services Inc		125.38
	06/08/2026	101 General	Supplies	Amazon Capital Services Inc		124.00
	06/08/2026	602 Sewer	Supplies	Amazon Capital Services Inc		206.16
	06/08/2026	101 General	Supplies	Amazon Capital Services Inc		104.88
	06/08/2026	101 General	Supplies	Amazon Capital Services Inc		505.95
	06/08/2026	101 General	Supplies	Amazon Capital Services Inc		-65.54

Check Number	Check Date	Fund	Account Name	Vendor Name	Void	Amount
	06/08/2026	234 Blight/Hazardous Mitigation	Expert & Professional Services	Asbestrol, Inc.		820.00
	06/08/2026	234 Blight/Hazardous Mitigation	Hazard Prop Removal-Assessed	Asbestrol, Inc.		853.74
	06/08/2026	101 General	Uniforms	Aspen Mills Incorporated		85.36
	06/08/2026	602 Sewer	Expert & Professional Services	Automatic Systems Company		7,219.00
	06/08/2026	101 General	Uniform Allowance	Jozie Bangert		1,100.00
	06/08/2026	101 General	Legal Services	Barna, Guzy & Steffen, Ltd		585.00
	06/08/2026	601 Water	Furniture, Equipment & Tools	Bomgaars Supply Inc		8.99
	06/08/2026	602 Sewer	Supplies	Bomgaars Supply Inc		380.97
	06/08/2026	701 CG - Vehicle & Equip Capital	Vehicles (Licensed)	Bomgaars Supply Inc		23.94
	06/08/2026	101 General	Building Maintenance	Bomgaars Supply Inc		20.87
	06/08/2026	101 General	Furniture, Equipment & Tools	Bomgaars Supply Inc		40.36
	06/08/2026	101 General	Supplies	Bomgaars Supply Inc		25.48
	06/08/2026	101 General	Furniture, Equipment & Tools	Bomgaars Supply Inc		49.98
	06/08/2026	701 CG - Vehicle & Equip Capital	Vehicles (Licensed)	Bomgaars Supply Inc		23.88
	06/08/2026	602 Sewer	Chemicals & Chemical Products	Bomgaars Supply Inc		190.49
	06/08/2026	101 General	Vehicle/Equipment Parts	Bomgaars Supply Inc		42.98
	06/08/2026	101 General	Building Maintenance	Bomgaars Supply Inc		56.99
	06/08/2026	602 Sewer	Supplies	Bomgaars Supply Inc		41.94
	06/08/2026	101 General	Building Maintenance	Bomgaars Supply Inc		35.99
	06/08/2026	101 General	Supplies	Bomgaars Supply Inc		35.99
	06/08/2026	101 General	Supplies	Bomgaars Supply Inc		5.98
	06/08/2026	101 General	Safety Equipment	Bomgaars Supply Inc		9.99
	06/08/2026	602 Sewer	Supplies	Bomgaars Supply Inc		35.98
	06/08/2026	101 General	Building Repair Supplies	Bomgaars Supply Inc		334.22
	06/08/2026	101 General	Furniture, Equipment & Tools	Bomgaars Supply Inc		24.99
	06/08/2026	234 Blight/Hazardous Mitigation	Expert & Professional Services	Braun Intertec Corporation		307.00
	06/08/2026	101 General	Rents & Leases	Canon Financial Services Inc		92.68
	06/08/2026	101 General	Books	Center Point, Inc		174.39
	06/08/2026	602 Sewer	Vehicle and Equipment Repairs	Champion Coatings Inc		7,600.00
	06/08/2026	101 General	Expert & Professional Services	Charter Communications Holdings LLC		50.00
	06/08/2026	412 Recreation Facilities Project	Building & Bldg Improvements	Chosen Valley Testing Inc		702.50
	06/08/2026	409 Storm Water Capital Projects	Expert & Professional Services	Chosen Valley Testing Inc		510.00
	06/08/2026	101 General	Supplies	Church Offset Printing, Inc		177.00
	06/08/2026	101 General	Supplies	Church Offset Printing, Inc		2,248.00
	06/08/2026	602 Sewer	Laundry Services	Cintas Corporation		115.91
	06/08/2026	602 Sewer	Laundry Services	Cintas Corporation		115.91
	06/08/2026	101 General	Laundry Services	Cintas Corporation		28.18
	06/08/2026	101 General	Laundry Services	Cintas Corporation		28.18
	06/08/2026	101 General	Laundry Services	Cintas Corporation		28.82
	06/08/2026	101 General	Laundry Services	Cintas Corporation		28.82
	06/08/2026	602 Sewer	Supplies	Cintas First Aid and Safety		57.86
	06/08/2026	101 General	Safety Equipment	Cintas First Aid and Safety		60.71
	06/08/2026	101 General	Rents & Leases	Coordinated Business Systems LTD		36.72
	06/08/2026	101 General	Rents & Leases	Coordinated Business Systems LTD		16.71

Check Number	Check Date	Fund	Account Name	Vendor Name	Void	Amount
	06/08/2026	101 General	Rents & Leases	Coordinated Business Systems LTD		43.87
	06/08/2026	601 Water	Supplies	Core & Main LP		2,589.88
	06/08/2026	601 Water	Supplies	Core & Main LP		1,693.04
	06/08/2026	601 Water	Supplies	Core & Main LP		1,942.08
	06/08/2026	601 Water	Supplies	Core & Main LP		372.48
	06/08/2026	602 Sewer	Supplies	Core & Main LP		109.43
	06/08/2026	101 General	Street Maintenance Materials	Croell, Inc.		1,415.25
	06/08/2026	101 General	Street Maintenance Materials	Croell, Inc.		973.63
	06/08/2026	101 General	Street Maintenance Materials	Croell, Inc.		1,053.25
	06/08/2026	101 General	Expert & Professional Services	Custom Communications, Inc.		195.00
	06/08/2026	101 General	Building Repair Supplies	Custom Communications, Inc.		262.00
	06/08/2026	101 General	Vehicle/Equipment Parts	Dave Syverson, Inc.		441.87
	06/08/2026	101 General	Vehicle/Equipment Parts	Dave Syverson, Inc.		19.56
	06/08/2026	101 General	Refuse Disposal	Elliott's Elite Lawn Care Services		125.00
	06/08/2026	101 General	Refuse Disposal	Elliott's Elite Lawn Care Services		250.00
	06/08/2026	101 General	Refuse Disposal	Elliott's Elite Lawn Care Services		250.00
	06/08/2026	101 General	Refuse Disposal	Elliott's Elite Lawn Care Services		125.00
	06/08/2026	101 General	Refuse Disposal	Elliott's Elite Lawn Care Services		125.00
	06/08/2026	101 General	Refuse Disposal	Elliott's Elite Lawn Care Services		250.00
	06/08/2026	101 General	Expert & Professional Services	Jamaira Escobar		600.00
	06/08/2026	101 General	Street Maintenance Materials	Falkstone LLC		1,195.42
	06/08/2026	101 General	Street Maintenance Materials	Falkstone LLC		3,873.13
	06/08/2026	601 Water	Supplies	Ferguson Enterprises, Inc.		55.26
	06/08/2026	601 Water	Supplies	Ferguson Enterprises, Inc.		460.40
	06/08/2026	601 Water	Supplies	Ferguson Enterprises, Inc.		108.00
	06/08/2026	601 Water	Supplies	Ferguson Enterprises, Inc.		695.73
	06/08/2026	101 General	Furniture, Equipment & Tools	Fire Safety USA Inc		2,319.85
	06/08/2026	701 CG - Vehicle & Equip Capital	Vehicles (Licensed)	Fire Safety USA Inc		1,019.95
	06/08/2026	701 CG - Vehicle & Equip Capital	Vehicles (Licensed)	Fire Safety USA Inc		182.75
	06/08/2026	101 General	Building Repair Supplies	Keith Flatness		1,088.37
	06/08/2026	101 General	Building Repair Supplies	Keith Flatness		913.95
	06/08/2026	602 Sewer	Motor Fuels	Freeborn County Co-op Oil Co. Inc.		3,222.97
	06/08/2026	101 General	Inventory - Fuel	Freeborn County Co-op Oil Co. Inc.		29,299.50
	06/08/2026	602 Sewer	Motor Fuels	Freeborn County Co-op Oil Co. Inc.		-178.24
	06/08/2026	101 General	Lubricants & Additives	Freeborn County Co-op Oil Co. Inc.		515.00
	06/08/2026	230 Economic Development	Building Maintenance	Freeborn County Environmental Services		40.00
	06/08/2026	401 Capital Project Revolving Fund	Engineering Services	Freeborn County Highway Department		4,099.66
	06/08/2026	401 Capital Project Revolving Fund	Engineering Services	Freeborn County Highway Department		2,232.75
	06/08/2026	401 Capital Project Revolving Fund	Engineering Services	Freeborn County Highway Department		6,243.30
	06/08/2026	701 CG - Vehicle & Equip Capital	Vehicles (Licensed)	Freeborn County Registrar		39.00
	06/08/2026	101 General	Taxes, License & Permit Fees	Freeborn County Registrar		16.25
	06/08/2026	101 General	Electric Utilities	Freeborn Mower Electric Cooperative		281.25
	06/08/2026	101 General	Electric Utilities	Freeborn Mower Electric Cooperative		1,110.24

Check Number	Check Date	Fund	Account Name	Vendor Name	Void	Amount
	06/08/2026	101 General	Electric Utilities	Freeborn Mower Electric Cooperative		3,693.21
	06/08/2026	101 General	Electric Utilities	Freeborn Mower Electric Cooperative		5,807.36
	06/08/2026	601 Water	Electric Utilities	Freeborn Mower Electric Cooperative		11,255.65
	06/08/2026	602 Sewer	Electric Utilities	Freeborn Mower Electric Cooperative		7,858.68
	06/08/2026	603 Solid Waste	Refuse Disposal	GFL Environmental Services USA LLC		175.43
	06/08/2026	601 Water	Expert & Professional Services	H & M Underground Solutions		36,329.33
	06/08/2026	101 General	Vehicle and Equipment Repairs	Hanson Tire Service of Albert Lea, Inc		105.00
	06/08/2026	101 General	Vehicle and Equipment Repairs	Hanson Tire Service of Albert Lea, Inc		105.00
	06/08/2026	603 Solid Waste	Refuse Disposal	Hanson Tire Service of Albert Lea, Inc		1,997.85
	06/08/2026	101 General	Vehicle and Equipment Repairs	Hanson Tire Service of Albert Lea, Inc		105.00
	06/08/2026	101 General	Vehicle and Equipment Repairs	Hanson Tire Service of Albert Lea, Inc		109.13
	06/08/2026	101 General	Vehicle and Equipment Repairs	Hanson Tire Service of Albert Lea, Inc		105.00
	06/08/2026	602 Sewer	Chemicals & Chemical Products	Hawkins, Inc.		1,155.10
	06/08/2026	602 Sewer	Chemicals & Chemical Products	Hawkins, Inc.		4,956.84
	06/08/2026	602 Sewer	Vehicle/Equipment Parts	Hawkins, Inc.		85.00
	06/08/2026	101 General	Supplies	Hilltop Greenhouse and Farm LLC		8,949.00
	06/08/2026	101 General	Supplies	Hilltop Greenhouse and Farm LLC		583.93
	06/08/2026	101 General	Supplies	Hilltop Greenhouse and Farm LLC		1,220.00
	06/08/2026	101 General	Supplies	Hillyard Inc.-Hutchinson		722.75
	06/08/2026	101 General	Supplies	Hillyard Inc.-Hutchinson		811.68
	06/08/2026	101 General	Supplies	Hillyard Inc.-Hutchinson		50.66
	06/08/2026	101 General	Supplies	Home Depot Credit Services		150.08
	06/08/2026	101 General	Building Repair Supplies	Home Depot Credit Services		339.00
	06/08/2026	101 General	Training/ Instruction Supplies	Home Depot Credit Services		57.14
	06/08/2026	101 General	Vehicle/Equipment Parts	Home Depot Credit Services		129.26
	06/08/2026	101 General	Supplies	Home Depot Credit Services		71.28
	06/08/2026	412 Recreation Facilities Project	Building & Bldg Improvements	Home Depot Credit Services		99.02
	06/08/2026	101 General	Supplies	Home Depot Credit Services		78.83
	06/08/2026	101 General	Supplies	Home Depot Credit Services		233.10
	06/08/2026	101 General	Supplies	Home Depot Credit Services		508.17
	06/08/2026	701 CG - Vehicle & Equip Capital	Vehicles (Licensed)	Home Depot Credit Services		129.30
	06/08/2026	101 General	Building Repair Supplies	Home Depot Credit Services		5.50
	06/08/2026	412 Recreation Facilities Project	Building & Bldg Improvements	Home Depot Credit Services		110.90
	06/08/2026	101 General	Supplies	Home Depot Credit Services		29.17
	06/08/2026	701 CG - Vehicle & Equip Capital	Vehicles (Licensed)	Home Depot Credit Services		217.07
	06/08/2026	101 General	Supplies	Home Depot Credit Services		77.61
	06/08/2026	412 Recreation Facilities Project	Building & Bldg Improvements	Home Depot Credit Services		34.34
	06/08/2026	101 General	Training/ Instruction Supplies	Home Depot Credit Services		58.31
	06/08/2026	603 Solid Waste	Refuse Disposal	I-35 Auto Recycling		200.00
	06/08/2026	495 2025 Projects	Improvements Other Than Bldgs	ICON LLC		12,751.66
	06/08/2026	495 2025 Projects	Cash and Investments	ICON LLC		-13,771.79
	06/08/2026	495 2025 Projects	Cash and Investments	ICON LLC		13,771.79
	06/08/2026	495 2025 Projects	City Engineering Charge	ICON LLC		1,020.13
	06/08/2026	101 General	Engineering Fees	ICON LLC		-1,020.13

Check Number	Check Date	Fund	Account Name	Vendor Name	Void	Amount
	06/08/2026	602 Sewer	Supplies	IDEXX Distribution, Inc.		2,289.46
	06/08/2026	101 General	Books	Ingram Library Services		208.11
	06/08/2026	101 General	Books	Ingram Library Services		333.61
	06/08/2026	101 General	Expert & Professional Services	Interstate Services, Inc		30.00
	06/08/2026	496 2026 Projects	Cash and Investments	Jensen Excavating & Trucking		-28,406.30
	06/08/2026	496 2026 Projects	Cash and Investments	Jensen Excavating & Trucking		2,104.17
	06/08/2026	101 General	Engineering Fees	Jensen Excavating & Trucking		-2,104.17
	06/08/2026	496 2026 Projects	Cash and Investments	Jensen Excavating & Trucking		28,406.30
	06/08/2026	496 2026 Projects	Improvements Other Than Bldgs	Jensen Excavating & Trucking		26,302.13
	06/08/2026	101 General	Building Maintenance	Jim & Dudes Plumbing & Heating, Inc.		402.60
	06/08/2026	412 Recreation Facilities Project	Machinery & Equipment	Jim & Dudes Plumbing & Heating, Inc.		13,030.00
	06/08/2026	602 Sewer	Vehicle/Equipment Parts	John Henry Foster Minnesota Inc		362.67
	06/08/2026	496 2026 Projects	Cash and Investments	Jones, Haugh & Smith Inc		-175.00
	06/08/2026	496 2026 Projects	Cash and Investments	Jones, Haugh & Smith Inc		175.00
	06/08/2026	496 2026 Projects	Expert & Professional Services	Jones, Haugh & Smith Inc		175.00
	06/08/2026	602 Sewer	Vehicle and Equipment Repairs	L & M Boiler Systems, Inc		9,255.00
	06/08/2026	101 General	Vehicle/Equipment Parts	Lawson Products Inc		161.08
	06/08/2026	101 General	Vehicle/Equipment Parts	Lawson Products Inc		367.86
	06/08/2026	101 General	Supplies	Leo Carey Post 56 American Legion		55.00
	06/08/2026	701 CG - Vehicle & Equip Capital	Vehicles (Licensed)	MacQueen Equipment LLC		4,237.55
	06/08/2026	701 CG - Vehicle & Equip Capital	Vehicles (Licensed)	MacQueen Equipment LLC		1,245.00
	06/08/2026	101 General	Vehicle/Equipment Parts	MacQueen Equipment LLC		274.43
	06/08/2026	701 CG - Vehicle & Equip Capital	Vehicles (Licensed)	MacQueen Equipment LLC		1,874.13
	06/08/2026	701 CG - Vehicle & Equip Capital	Vehicles (Licensed)	MacQueen Equipment LLC		421.73
	06/08/2026	101 General	Vehicle/Equipment Parts	MacQueen Equipment LLC		5,223.06
	06/08/2026	602 Sewer	Supplies	McMaster-Carr Supply Company		471.74
	06/08/2026	101 General	Safety Equipment	MES I Acquisition Inc		18.37
	06/08/2026	101 General	Safety Equipment	MES I Acquisition Inc		25,986.00
	06/08/2026	101 General	Safety Equipment	MES I Acquisition Inc		1,504.50
	06/08/2026	101 General	Safety Equipment	MES I Acquisition Inc		610.36
	06/08/2026	101 General	Building Maintenance	Midwest Industrial Tanks		6,800.00
	06/08/2026	101 General	Periodicals & Magazines	Milk Street Magazine		69.90
	06/08/2026	101 General	Engineering Services	Minnesota Department of Transportation		1,647.19
	06/08/2026	230 Economic Development	Building Maintenance	Minnesota Elevator Inc		63.29
	06/08/2026	101 General	Building Maintenance	Minnesota Elevator Inc		110.71
	06/08/2026	101 General	Building Maintenance	Minnesota Elevator Inc		79.11
	06/08/2026	601 Water	Gas Utilities	Minnesota Energy Resources		22.82
	06/08/2026	101 General	Gas Utilities	Minnesota Energy Resources		27.87
	06/08/2026	101 General	Gas Utilities	Minnesota Energy Resources		47.93
	06/08/2026	101 General	Gas Utilities	Minnesota Energy Resources		35.90
	06/08/2026	601 Water	Gas Utilities	Minnesota Energy Resources		139.06
	06/08/2026	225 Airport	Gas Utilities	Minnesota Energy Resources		1,168.04
	06/08/2026	101 General	Gas Utilities	Minnesota Energy Resources		18.81
	06/08/2026	602 Sewer	Gas Utilities	Minnesota Energy Resources		216.98

Check Number	Check Date	Fund	Account Name	Vendor Name	Void	Amount
	06/08/2026	101 General	Gas Utilities	Minnesota Energy Resources		47.65
	06/08/2026	101 General	Gas Utilities	Minnesota Energy Resources		19.84
	06/08/2026	101 General	Gas Utilities	Minnesota Energy Resources		225.15
	06/08/2026	101 General	Gas Utilities	Minnesota Energy Resources		27.87
	06/08/2026	601 Water	Gas Utilities	Minnesota Energy Resources		60.37
	06/08/2026	101 General	Gas Utilities	Minnesota Energy Resources		35.82
	06/08/2026	101 General	Gas Utilities	Minnesota Energy Resources		18.81
	06/08/2026	225 Airport	Gas Utilities	Minnesota Energy Resources		91.19
	06/08/2026	101 General	Gas Utilities	Minnesota Energy Resources		76.60
	06/08/2026	101 General	Gas Utilities	Minnesota Energy Resources		18.81
	06/08/2026	101 General	Gas Utilities	Minnesota Energy Resources		51.18
	06/08/2026	101 General	Training & Education	MN Bureau of Criminal Apprehension		300.00
	06/08/2026	101 General	Training & Education	MN Bureau of Criminal Apprehension		300.00
	06/08/2026	101 General	Supplies	M-R Sign Co., Inc.		2,708.30
	06/08/2026	101 General	Vehicle and Equipment Repairs	North Central International LLC		530.49
	06/08/2026	101 General	Building Maintenance	Olympic Fire Protection Corp		480.00
	06/08/2026	225 Airport	Building Maintenance	Overhead Door Company of Albert Lea		585.00
	06/08/2026	101 General	Vehicle and Equipment Repairs	Park & Play USA LLC		610.05
	06/08/2026	101 General	Building Maintenance	Plunkett's Pest Control Inc		96.08
	06/08/2026	101 General	Tires	Pomp's Tire Service Inc		198.23
	06/08/2026	101 General	Vehicle and Equipment Repairs	Pomp's Tire Service Inc		72.78
	06/08/2026	101 General	Expert & Professional Services	Protect Youth Sports		109.50
	06/08/2026	412 Recreation Facilities Project	Improvements Other Than Bldgs	Quality Pools LLC		15,000.00
	06/08/2026	101 General	Telephone & Internet	Qwest Corporation		116.66
	06/08/2026	101 General	Vehicle and Equipment Repairs	R & R Truck Repair Inc		573.10
	06/08/2026	101 General	Vehicle and Equipment Repairs	R & R Truck Repair Inc		578.00
	06/08/2026	101 General	Vehicle and Equipment Repairs	R & R Truck Repair Inc		1,044.79
	06/08/2026	101 General	Vehicle and Equipment Repairs	R & R Truck Repair Inc		540.95
	06/08/2026	101 General	Supplies	Reinders Inc		312.50
	06/08/2026	101 General	Expert & Professional Services	Rohn Industries, Inc		77.37
	06/08/2026	101 General	Vehicle/Equipment Parts	Safety Technologies Inc		212.20
	06/08/2026	101 General	Supplies	Schilling Supply Company		124.21
	06/08/2026	101 General	Building Maintenance	Sherwin-Williams		77.44
	06/08/2026	601 Water	Supplies	Sherwin-Williams		48.95
	06/08/2026	401 Capital Project Revolving Fund	Engineering Services	Short Elliott Hendrickson Inc.		2,285.46
	06/08/2026	101 General	Expert & Professional Services	Sir Lines-A-Lot LLC		17,163.90
	06/08/2026	401 Capital Project Revolving Fund	Machinery & Equipment	Solar Connection Inc		71,457.00
	06/08/2026	101 General	Uniforms	Streicher's		116.99
	06/08/2026	101 General	Uniforms	Streicher's		1,993.00
	06/08/2026	101 General	Uniforms	Streicher's		2,038.97
	06/08/2026	602 Sewer	Vehicle/Equipment Parts	Thompson Electric		480.67
	06/08/2026	234 Blight/Hazardous Mitigation	Hazard Prop Removal-Assessed	Thompson Sanitation, Inc.		27.58
	06/08/2026	101 General	Supplies	US LBM Operating Co 3009 LLC		170.82
	06/08/2026	101 General	Supplies	US LBM Operating Co 3009 LLC		18.94

Check Number	Check Date	Fund	Account Name	Vendor Name	Void	Amount
	06/08/2026	101 General	Supplies	US LBM Operating Co 3009 LLC		82.28
	06/08/2026	101 General	Telephone & Internet	Verizon Wireless Services LLC		40.01
	06/08/2026	601 Water	Telephone & Internet	Verizon Wireless Services LLC		35.01
	06/08/2026	601 Water	Telephone & Internet	Verizon Wireless Services LLC		35.01
	06/08/2026	602 Sewer	Telephone & Internet	Verizon Wireless Services LLC		35.01
	06/08/2026	101 General	Telephone & Internet	Verizon Wireless Services LLC		40.01
	06/08/2026	101 General	Telephone & Internet	Verizon Wireless Services LLC		51.77
	06/08/2026	601 Water	Telephone & Internet	Verizon Wireless Services LLC		35.01
	06/08/2026	601 Water	Telephone & Internet	Verizon Wireless Services LLC		40.01
	06/08/2026	101 General	Telephone & Internet	Verizon Wireless Services LLC		35.01
	06/08/2026	601 Water	Telephone & Internet	Verizon Wireless Services LLC		35.01
	06/08/2026	101 General	Telephone & Internet	Verizon Wireless Services LLC		51.77
	06/08/2026	601 Water	Telephone & Internet	Verizon Wireless Services LLC		35.01
	06/08/2026	601 Water	Telephone & Internet	Verizon Wireless Services LLC		35.01
	06/08/2026	602 Sewer	Telephone & Internet	Verizon Wireless Services LLC		35.01
	06/08/2026	101 General	Telephone & Internet	Verizon Wireless Services LLC		40.01
	06/08/2026	601 Water	Telephone & Internet	Verizon Wireless Services LLC		35.01
	06/08/2026	601 Water	Telephone & Internet	Verizon Wireless Services LLC		40.01
	06/08/2026	101 General	Building Repair Supplies	Kelly Wangsness		258.91
	06/08/2026	101 General	Supplies	Kelly Wangsness		480.00
	06/08/2026	101 General	Supplies	Kelly Wangsness		25.00
	06/08/2026	701 CG - Vehicle & Equip Capital	Vehicles (Licensed)	Kelly Wangsness		75.00
	06/08/2026	101 General	Supplies	Kelly Wangsness		325.00
	06/08/2026	601 Water	Supplies	Kelly Wangsness		480.00
	06/08/2026	101 General	Expert & Professional Services	Waste Management of WI-MN		2,288.44
	06/08/2026	603 Solid Waste	Telephone & Internet	Winnebago Cooperative Telecom Assn		73.06
	06/08/2026	602 Sewer	Supplies	Winsupply Albert Lea MN Co		40.19
	06/08/2026	101 General	Lubricants & Additives	World Fuel Services Inc		514.25
	06/08/2026	602 Sewer	Supplies	WW Goetsch Associates Inc		2,242.63

Report Total: 1,283,031.83